

Prisma



PNEUMATIC ACTUATORS

PRISMA

The company	1
Certifications	2

ALUMINIUM PNEUMATIC ACTUATORS

Technical features	3
PA range	5
P range	7
Disassembly and materials	9
PA dimensions	11
P dimensions	12
Cycle time, weights and capacity	13
Operating torque	13

POLYAMIDE PNEUMATIC ACTUATORS

Technical features	15
PP range	17
Disassembly and materials	19
PP dimensions	20
Cycle time, weights and capacity	21
Operating torque	22

STAINLESS STEEL PNEUMATIC ACTUATORS

Technical features	23
PI range	25
Disassembly and materials	27
PI dimensions	28
Cycle time, weights and capacity	29
Operating torque	30

SPECIAL ACTUATORS

180° rotation actuators	31
High and low temperature actuators	32
Fail open actuators	32
Reverse actuators	32
Shaft mounted at 90°	32
Stainless Steel options	32

HEAVY DUTY PNEUMATIC ACTUATORS

Technical features	33
Disassembly and materials	34
PD range	35
PD dimensions	37
Operating torque	38

MOUNTING KITS, ELECTRIC ACTUATORS AND ELEMENTS OF REGULATION AND CONTROL

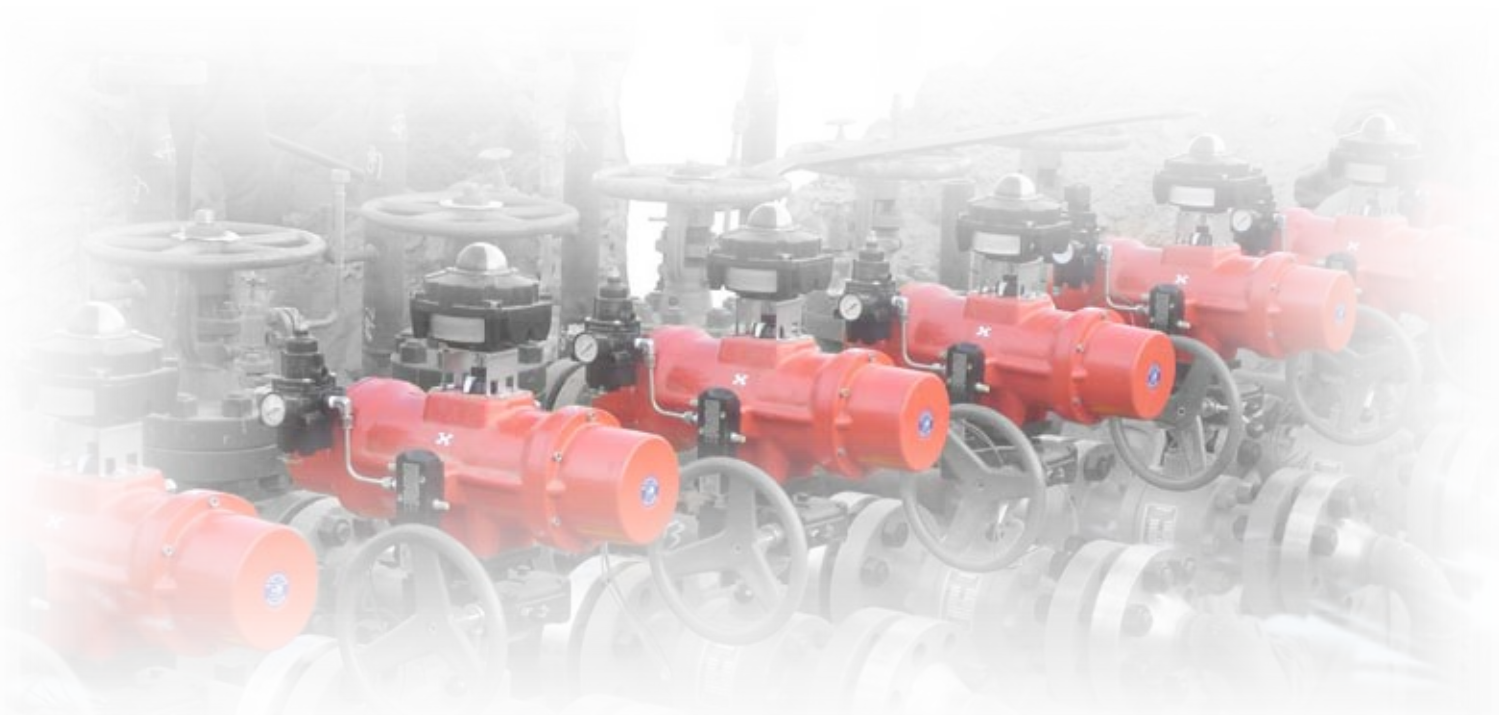

The brand name of **PRISMA** Actuators has become well-known all around the world and is now a point of reference in this industry because of the robustness and reliability of its products. This success relies on continuously improving the quality and enhancing the development of our products and also to tailoring our service to meet the individual requirements of every one of our customers.

Since it was founded in 1980, PRISMA has grown remarkably. In recent times our mechanical know-how as well as our extensive technical knowledge has evolved to offer complete solutions in the automation of valves to control the process of fluid conduction.

MECÁNICA PRISMA develops four Pneumatic Actuator ranges, according to different environments of application: Aluminium, Stainless Steel, Polyamide and for High Temperatures. All manufactured according to international norms such as: ISO, DIN, NAMUR, VDE, VDI, ATEX, CE, DNV, PCT, SIL2.

MECÁNICA PRISMA is accredited by quality norm ISO 9001-2000, ISO-TS-29001, API Q1 and 65% of its production is exported to more than 45 countries worldwide.



PRISMA offers a wide range of products for valve automation including pneumatic actuators, electric actuators and elements of regulation and control: solenoid valves, limit switch boxes, positioners, travel stops, declutchable gearboxes, handwheels, etc.

All actuators can be mounted onto any kind of valve, due to the wide range of mounting kits that PRISMA develops and produces.

PRISMA pneumatic actuators are available in double acting and spring return, covering a torque range from 17Nm to 65.000Nm at 6 Bar. Industrial applications: Chemical, Nuclear, Electronics, Automotive, Food and Beverage, Pharmaceutical; and other sectors such as Iron and Steel, Power Plants, Water Treatment, Oil & Gas, Off-Shore plants, etc.

CERTIFICATIONS



ISO-9001 / TS 29001 / API Q1

IEC-61508-SIL-2

PED-PA60-PA70-BV



TAC-DNV

TAC-DNV-PA

PH-94007802-LGAI



ATEX-LOM



ATEX-LOM-PA



GOST CERTIFICATE

ALUMINIUM PNEUMATIC ACTUATORS

TECHNICAL FEATURES

Rotation Angle and Torques

Aluminium actuators, 0°-90° or 0°-180° rotation angle to pilot ball, butterfly and plug valves. Broad range of actuators, both Double Acting and Spring Return, from 17 to 5000 Nm at 6 bar.

INTERNALLY AND EXTERNALLY COATED BY CATAPHORESIS + RILSAN

Manufactured with materials resistant to oxidation. Silicone free.

DOUBLE CORROSION RESISTANCE guaranteed.

CATAPHORESIS

Electrochemical process that provides high corrosion resistance by means of 20 microns of uniform epoxy resin surface

RILSAN

Polyamide 11 coating (250 microns). Offers high resistance to corrosion, wearing and impacts.

Resistance to Saline Smog Room:
B-117-73 > 1000h.

Spring Security System

Spring Security System, making manipulation and mounting easy and safe. All components are protected against corrosion.



17Nm

Pressure

May be actioned with air or any nonaggressive fluid up to 8 bar pressure (up to 15 bar, on demand).

Normal Working Temperature

-32°C to +90°C (-50°C to +90°C, on demand).

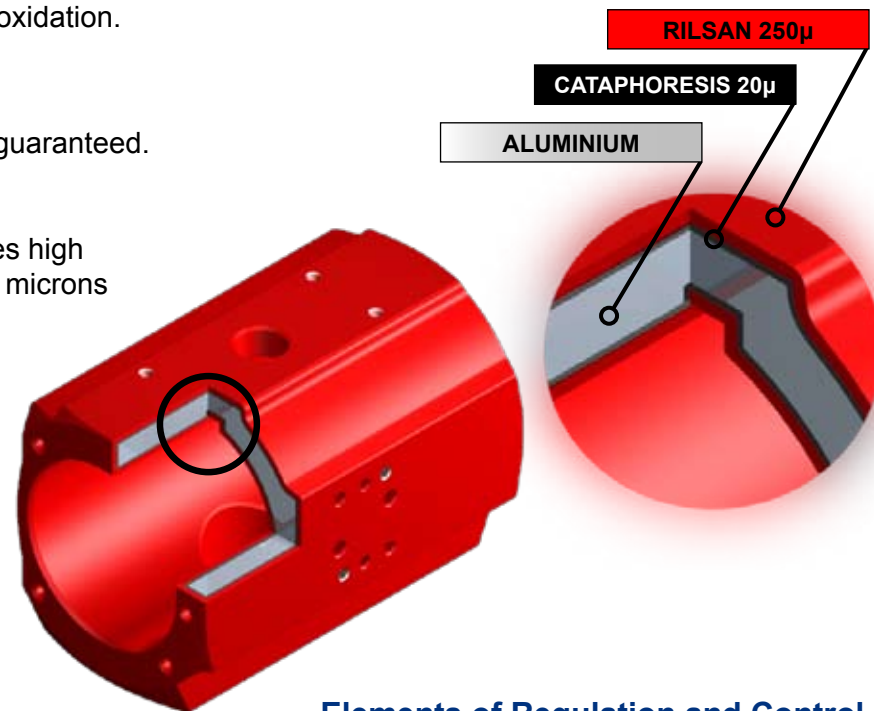

Elements of Regulation and Control

May be equipped with limit switches, solenoid valve, positioner and manual override by wheel or declutchable gearbox.

Stroke Adjustments

External stroke adjustments to regulate opening (+85° to +92°) and closing (-2° to +5°) of the valve, both in double acting and spring return. Predominately used in butterfly valves, to adjust closing of the disc.

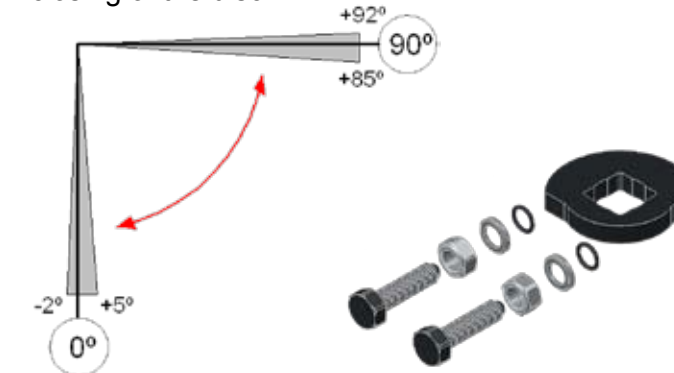

Directives

Conforming to all International Directives: ISO, DIN, NAMUR, VDI/VDE, ATEX, CE, DNV, PCT.

NAMUR Pneumatic connection for solenoid valve installation

VDI/VDE 3845 norms fixator to mount accessories.

Conforms to ISO-5211 and DIN-3337 specifications for easy mounting of most of the valves.

Prisma Pneumatic Actuators are manufactured under the requirements of PED 97-23-EC and ATEX 94-9-EC Directive.

ATEX EXII2GDT6 Certification.



Mounting Kits

Broad range of couplings for any kind of valve adaptation.

Applications

Designed for a wide range of Industrial applications: Chemical, Nuclear, Electronics, Automotive, Food and Beverage, Pharmaceutical; and other sectors such as Iron and Steel, Power Plants, Water Treatment, Oil & Gas, Off-Shore plants, etc.

ALUMINIUM PNEUMATIC ACTUATORS

PA RANGE

SHAFT

Shaft End according to:
VDI/VDE 3845 (NAMUR).

PISTONS

CATAPHORESIS COATED
Wearing strips in pistons, allowing
low friction and long life of the actuator.

BODY AND CAPS

With external and internal coating
(CATAPHORESIS + RILSAN
or POLYURETHANE (caps)),
double corrosion resistance.

STROKE ADJUSTMENTS

Standard for all models except
PAW. The two independent
external travel stop adjustment
bolts can adjust $+2^\circ$ / -5° in both
open and close directions.

SPRINGS

Preloaded spring with
security system, allowing
the ability to interchange
the springs.

PNEUMATIC CONNECTION PLATE

Pneumatic connection versatility: 1/4" BSP
(Options: 1/4" NPT and AISI-316 material).

Dimensions according to
VDI/VDE 3845 (NAMUR)

END CAPS

Stainless steel bolt fastening.
Same cap for double acting
and spring return models.

SHAFT

Double o-ring.
Shaft exit: ISO-5211.
Option: Aisi-303 Stainless Steel.

VALVE FIXATION

ISO-5211 Double Norm in all models.

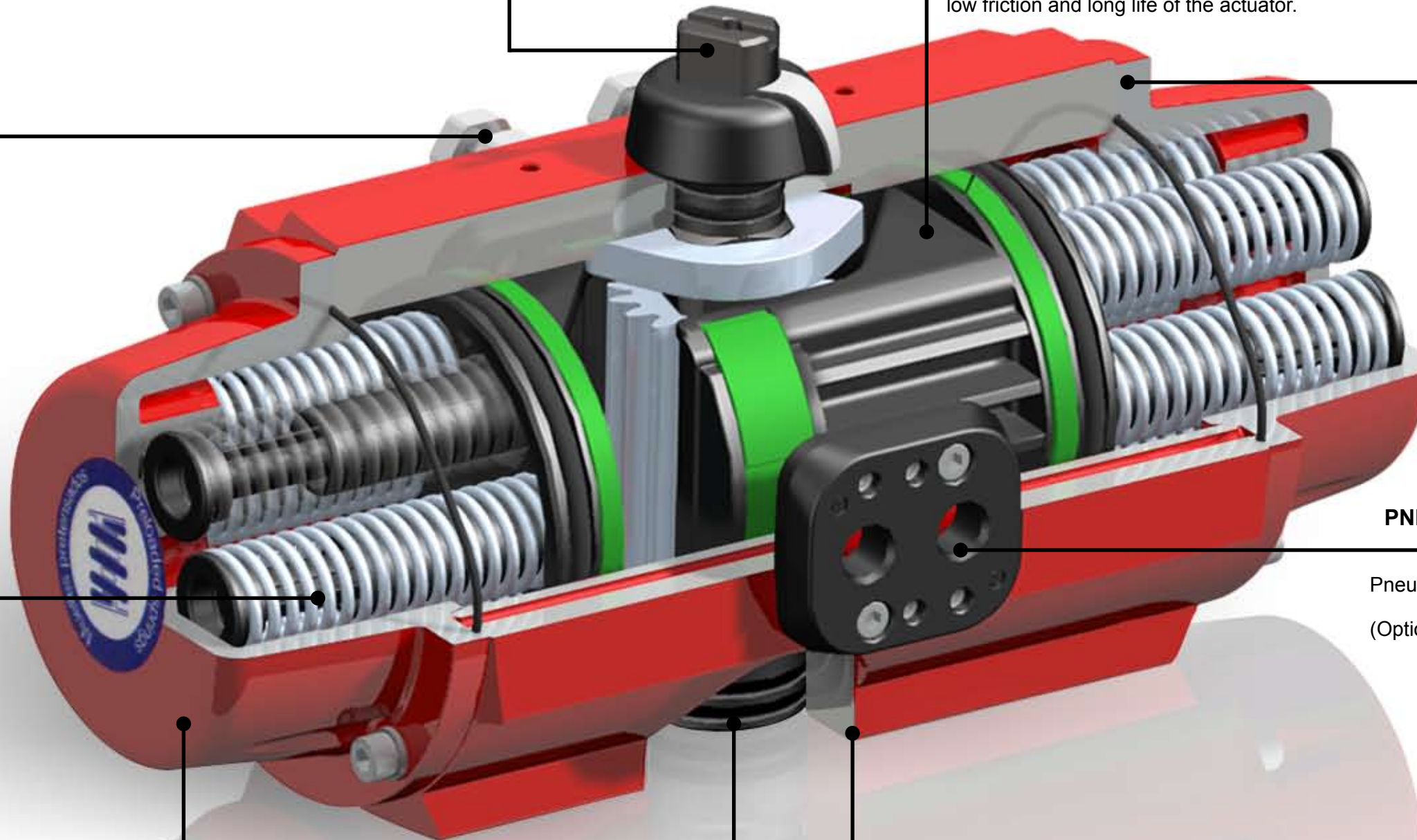

ALUMINIUM PNEUMATIC ACTUATORS

P RANGE

SHAFT

Shaft End according to:
VDI/VDE 3845 (NAMUR)

STROKE ADJUSTMENTS

Optional for P Actuators. The two independent external travel stop adjustment bolts can adjust $+2^{\circ}/-5^{\circ}$ in both open and close directions.

SPRINGS

Concentric spring set, with security system as an option.

CAPS

Stainless steel bolt fastening.
Different cap for double acting and spring return models.

PISTONS

Wearing strips in pistons, allowing low friction and long life of the actuator.

BODY AND CAPS

With external and internal coating (CATAPHORESIS + RILSAN), double corrosion resistance.

PNEUMATIC CONNECTION

Pneumatic connection 1/4" BSP
Dimensions according to VDI/VDE 3845 (NAMUR).

VALVE FIXATION

ISO-5211 Norm in all models.

SHAFT

Double o-ring.
Shaft exit: ISO-5211.

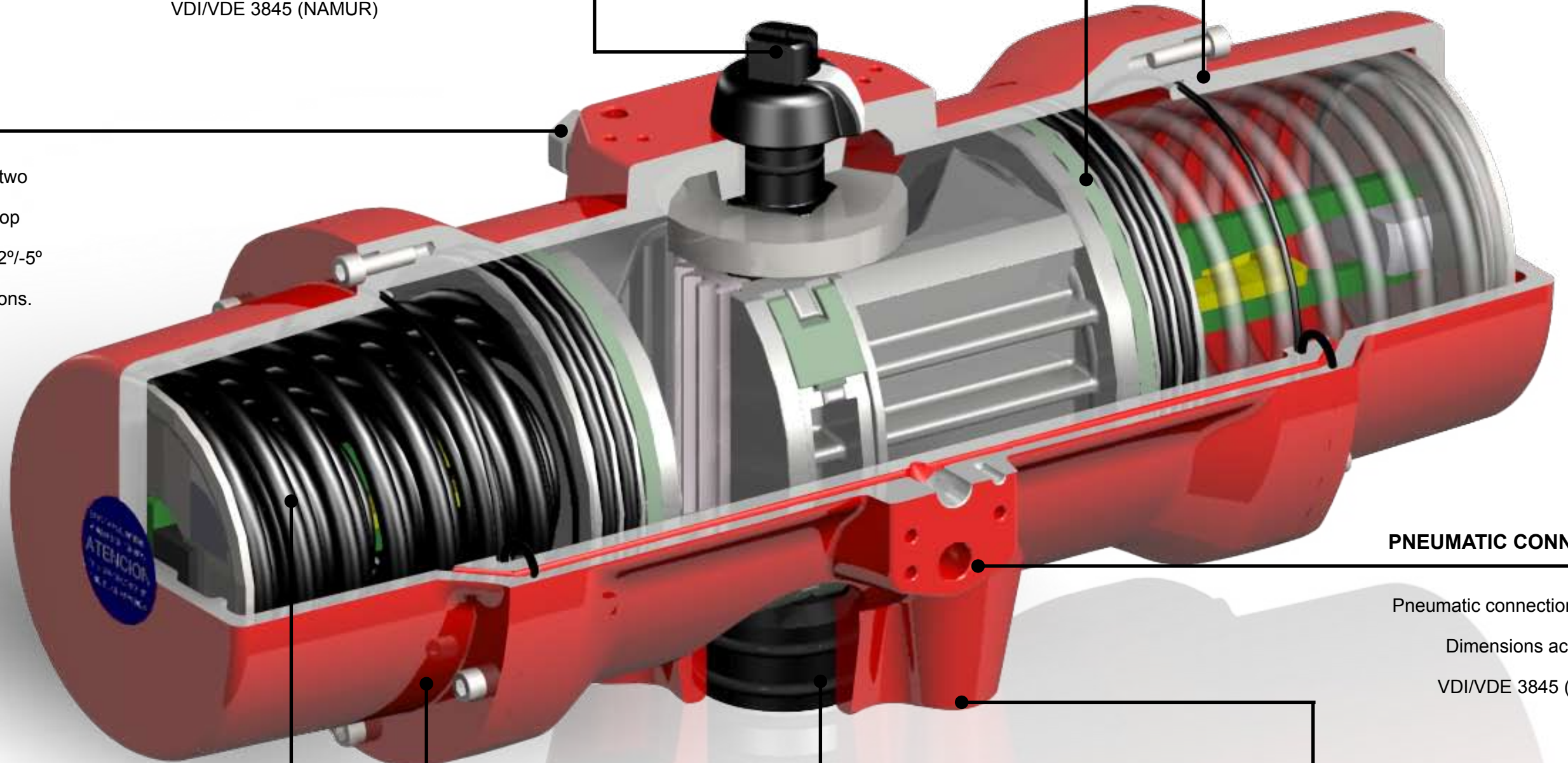

ALUMINIUM PNEUMATIC ACTUATORS

DISASSEMBLY AND MATERIALS

PA

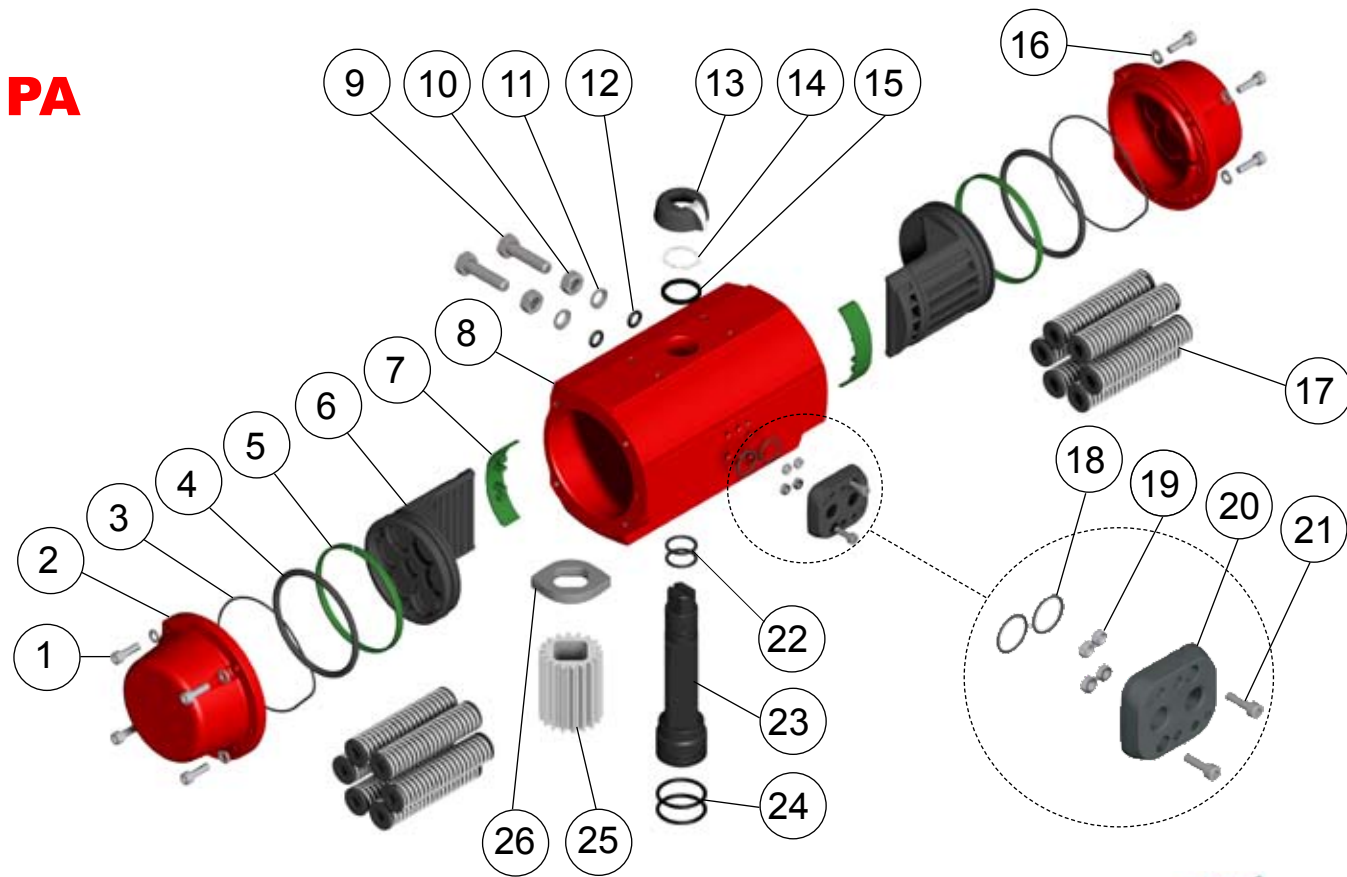

P

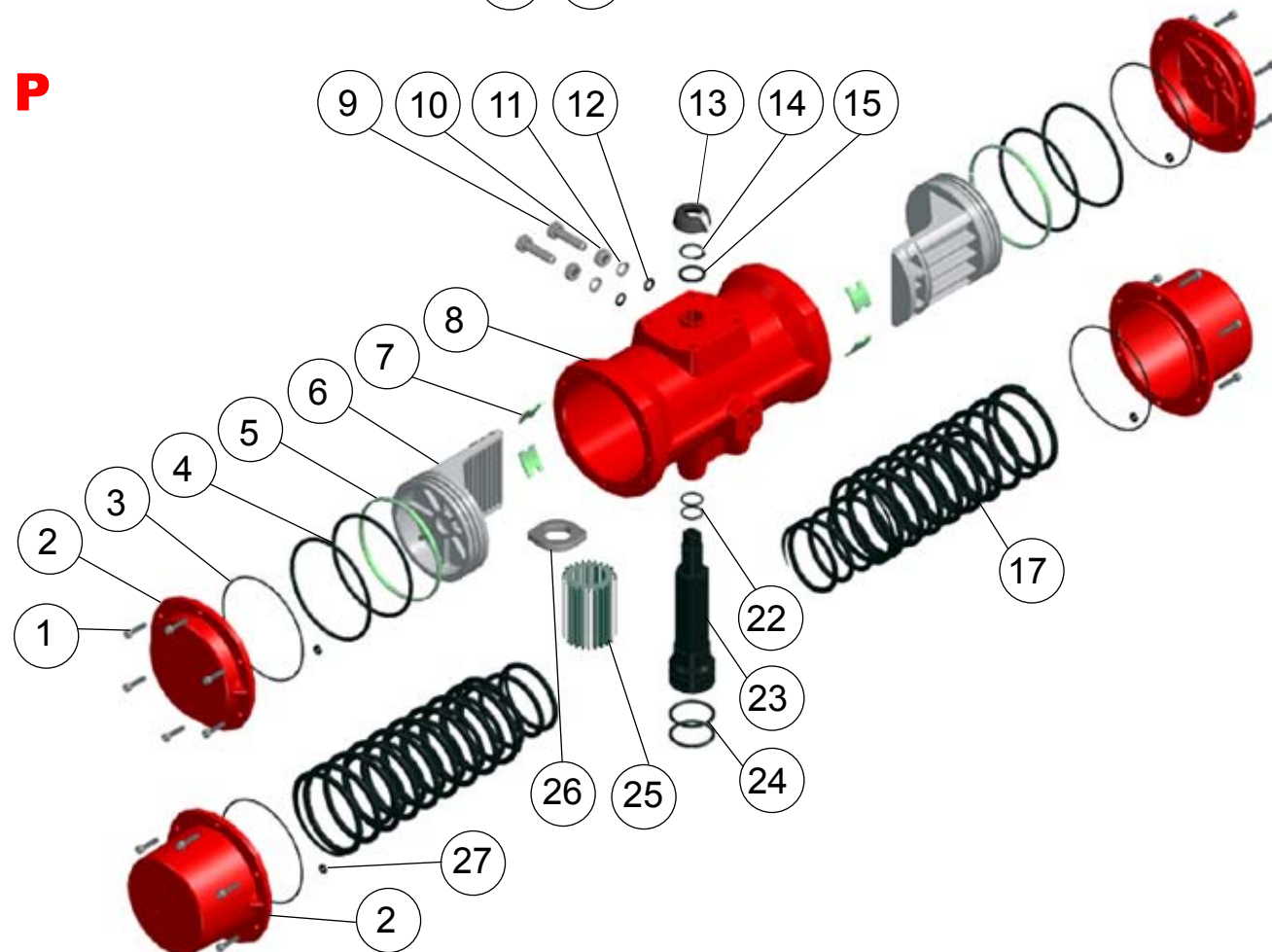

N°	DESCRIPTION	QUANTITY	MATERIAL	SURFACE FINISH
1	CAP ALLEN SCREW	8-12-16-20	AISI-304 STAINLESS STEEL	-
2	CAP	2	ALUMINIUM ALLOY	CATAPHORESIS + POLYURETHANE (PA) CATAPHORESIS + RILSAN (P-PA60-PA70)
3	CAP O-RING	2 - 4	N.B.R.	-
4	PISTON O-RING	2	N.B.R.	-
5	GUIDE RING	2	POLYACETAL (PA) P.T.F.E + BRONZE (P)	-
6	PISTON	2	ALUMINIUM ALLOY POLYARILAMIDE (PAW)	CATAPHORESIS COVERED (PA)
7	PISTON GUIDE	2 - 4	POLYACETAL (PA except PAW) P.T.F.E + BRONZE (P)	-
8	CYLINDER	1	ALUMINIUM ALLOY	CATAPHORESIS + RILSAN COVERED
9	HEXAGONAL SCREW	2	INOX. A2 (PA RANGE - P30) STEEL (P40-P50-PA70)	-
10	NUT	2	AISI-304 STAINLESS STEEL	-
11	BUSHING	2	AISI-304 STAINLESS STEEL	-
12	O-RING	2	N.B.R.	-
13	POSITION INDICATOR	1	POLYAMIDE	-
14	SPRING CLIP	1	STEEL	NIQUEL-P.T.F.E COVERED
15	BUSHING	1	POLYAMIDE 6	-
16	CAP WASHER	8	AISI-304 STAINLESS STEEL	-
17	SPRING SET	0-12	DIN-17223-C	TRIVALENT Cr PASSIVATION (PA) CATAPHORESIS COVERED (P)
18	PLATE O-RING	2	N.B.R.	-
19	NUT	4	AISI-304 STAINLESS STEEL	-
20	PNEUMATIC CONNECTION PLATE	1	POLYAMIDE + FG AISI-316 S.S (PA70)	-
21	PLATE ALLEN SCREW	2	AISI-304 STAINLESS STEEL	-
22	SHAFT O-RING	2	N.B.R.	-
23	SHAFT	1	STEEL POLYAMIDE (PAW)	CATAPHORESIS COVERED (except PAW)
24	SHAFT O-RING	2	N.B.R.	-
25	GEAR	1	ALUMINIUM ALLOY	BALL BURNISHING
26	CAM	1	STEEL	CATAPHORESIS COVERED
27	WATERTIGHT PLANE GASKET	2	N.B.R.	-

ALUMINIUM PNEUMATIC ACTUATORS

CYCLE TIME, WEIGHTS AND CAPACITY

MODELS		CYCLE TIME (sec.)				WEIGHTS (Kg)		CAPACITY (litre)			
DA	SR	TO OPEN		TO CLOSE		DA	SR	TO OPEN		TO CLOSE	
		DA	SR	DA	SR			DA	SR	DA	SR
PAW	PAWS	0,1	0,15	0,1	0,15	0,92	1	0,075	0,075	0,11	-
PA00	PA00S	0,15	0,2	0,15	0,2	1,40	1,625	0,15	0,15	0,18	-
PA05	PA05S	0,2	0,25	0,2	0,25	2,57	2,94	0,28	0,28	0,37	-
PA10	PA10S	0,25	0,3	0,25	0,3	3,08	3,48	0,35	0,35	0,45	-
PA15	PA15S	0,3	0,4	0,3	0,4	4,20	5,04	0,65	0,65	0,82	-
PA20	PA20S	0,4	0,5	0,4	0,5	5,61	6,63	0,8	0,8	1,15	-
PA25	PA25S	0,5	0,8	0,5	0,8	9,30	11,30	1,5	1,5	2,02	-
P30	P30S	0,6	1,2	0,6	1,2	9,1	15,9	2,05	2,05	1,9	-
P40	P40S	1,2	2	1,2	2	17,6	36,4	5,3	5,3	5,3	-
P50	P50S	2	6	2	6	30,7	58,4	10,5	10,5	7	-
PA60	PA60S	3	6	3	5	48,3	64,8	19,5	19,5	20,7	-
PA70	PA70S	4	8	4	6	77,9	118,2	31	31	30	-

OPERATING TORQUE

MODELS	DOUBLE ACTING (DA)						
	Air torque at indicated pressure (bar)						
	3	4	5	5,5	6	7	8
PAW	7,9	11,3	14,1	15,5	17	19,8	22,9
PA00	11,6	16,1	20,5	22,7	25	29,5	33,9
PA05	23,5	32,3	41	45,3	49,7	58,4	67,1
PA10	32,9	45,6	58,3	65	71	83,7	96,4
PA15	55,2	75,6	96	106,2	116,5	136,9	157,4
PA20	77,7	107	136,3	151	165,5	194,8	224
PA25	140,1	190,1	240	264,9	290	339,9	393,9
P30	226,5	307,4	388,3	428,7	469,2	550,1	631
P40	582,5	781,6	980,8	1080	1180	1379	1578
P50	998	1354	1711	1889	2067	2424	2780
PA60	1638	2245	2851	3155	3458	4065	4672
PA70	2389	3273	4158	4600	5043	5927	6812

Units: Nm

SPRING POSITIONING (PA RANGE)

Application in installations with air pressure less than 6 bar. Springs positioned from 2 to 6 springs each side, distributed as indicated in the drawing.



SPRING RETURN (SR)

MODELS	Springs Number	Spring Torques (Nm)		Air torque at indicated pressure (bar)													
		Initial	End	3		4		5		5,5		6		7		8	
				Initial	End	Initial	End	Initial	End	Initial	End	Initial	End	Initial	End	Initial	End
PAWS	6 + 6	10	6,7					7,4	4,1	8,8	5,5	10,3	7	13,1	9,8	16,2	12,9
	5 + 5	8,5	5,8			5,5	2,8	8,3	5,6	9,7	7	11,2	8,5	14	11,3	17,1	14,4
	4 + 4	7	4,6	3,3	0,9	6,7	4,3	9,5	7,1	10,9	8,5	12,4	10	15,2	12,8	18,3	15,9
	3 + 3	5,5	3,6	4,3	2,4	7,7	5,8	10,5	8,6	11,9	10	13,4	11,5	16,2	14,3		
	2 + 2	4	2,4	5,5	3,9	8,9	7,3	11,7	10,1	13,1	11,5	14,6	13				
PA00S	6 + 6	16,5	11,1					9,4	4	11,3	6,2	13,9	8,5	18,4	13	22,8	17,4
	5 + 5	13,8	9,4			6,7	2,3	11,1	6,7	13,3	8,9	15,6	11,2	20,1	15,7	24,5	20,1
	4 + 4	11,1	7,6			8,5	5	12,9	9,4	15,1	11,6	17,4	13,9	21,9	18,4	26,3	22,8
	3 + 3	8,5	5,8	5,8	3,1	10,3	7,6	14,7	12	16,9	14,2	19,2	16,5	23,7	21		
	2 + 2	5,8	3,6	8	5,8	12,5	10,3	16,9	14,7	19,1	16,9	21,4	19,2				
PA05S	6 + 6	31,4	20,9					20,1	9,6	24,4	13,9	28,8	18,3	37,5	27	46,2	35,7
	5 + 5	27	17,4			14,9	5,3	23,6	14	27,9	18,3	32,3	22,7	41	31,4	49,7	40,1
	4 + 4	21,8	13,9	9,6	1,7	18,4	10,5	27,1	19,2	31,4	23,5	35,8	27,9	44,5	36,6	53,2	45,3
	3 + 3	18,3	11,3	12,2	5,2	21	14	29,7	22,7	34	27	38,4	31,4	47,1	40,1		
	2 + 2	12,2	7,8	15,7	11,3	24,5	20,1	33,2	28,8	37,5	33,1	41,9	37,5				
PA10S	6 + 6	45,6	30,8					27,5	12,7	34,2	19,4	40,2	25,4	52,9	38,1	65,6	50,8
	5 + 5	38	25,7			19,9	7,6	32,6	20,3	39,3	27	45,3	33	58	45,7	70,7	58,4
	4 + 4	30,4	20,5	12,4	2,5	25,1	15,2	37,8	27,9	44,5	34,6	50,5	40,6	63,2	53,3	75,9	66
	3 + 3	22,8	15,4	17,5	10,1	30,2	22,8	42,9	35,5	49,6	42,2	55,6	48,2	68,3	60,9		
	2 + 2	15,2	10,3	22,6	17,7	35,3	30,4	48	43,1	54,7	49,8	60,7	55,8				
PA15S	6 + 6	71,5	49					47	24,5	57,2	34,7	67,5	45	87,9	65,4	108,4	85,9
	5 + 5	59,6	40,9			34,7	16	55,1	36,4	65,3	46,6	75,6	56,9	96	77,3	116,5	97,8
	4 + 4	47,7	32,7	22,5	7,5	42,9	27,9	63,3	48,3	73,5	58,5	83,8	68,8	104,2	89,2	124,7	109,7
	3 + 3	35,7	24,5	30,7	19,5	51,1	39,9	71,5	60,3	81,7	70,5	92	80,8	112,4	101,2		
	2 + 2	23,8	16,3	38,9	31,4	59,3	51,8	79,7	72,2	89,9	82,4	100,2	92,7				
PA20S	6 + 6	104,7	65,8					70,5	31,6	85,2	46,3	99,7	60,8	129	90,1	158,2	119,3
	5 + 5	87,2	54,8			52,2	19,8	81,5	49,1	96,2	63,8	110,7	78,3	140	107,6	169,2	136,8
	4 + 4	69,8	43,9	33,8	8	63,1	37,2	92,4	66,5	107,1	81,2	121,6	95,7	150,9	125	180,1	154,2
	3 + 3	52,3	32,9	44,8	25,4	74,1	54,7	103,4	84	118,1	98,7	132,6	113,2	161,9	142,5		
	2 + 2	34,9	21,9	55,8	42,8	85,1	72,1	114,4	101,4	129,1	116,1	143,6	130,6				
PA25S	6 + 6	181,8	119,4					120,6	58,2	145,5	83,1	170,6	108,2	220,5	158,1	274,5	212,1
	5 + 5	151,5	99,5			90,6	38,6	140,5	88,5	165,4	113,4	190,5	138,5	240,4	188,4	294,4	242,4
	4 + 4	121,2	79,6	60,5	18,9	110,5	68,9	160,4	118,8	185,3	143,7	210,4	168,8	260,3	218,7	314,3	272,7
	3 + 3	90,9	59,7	80,4	49,2	130,4	99,2	180,3	149,1	205,2	174	230,3	199,1	280,2	249		
	2 + 2	60,6	39,8	100,3	79,5	150,3	129,5	200,2	179,4	225,1	204,3	250,2	229,4				
P30S	4 + 4	273,7	179,9			127,5	33,7	208,4	114,6	248,9	155,1	289,3	195,5	370,2	276,4	451,1	357,3
	3 + 3	203,3	140,8	85,8	23,2	166,6	104,1	247,5	185	288	225,5	328,4	265,9	409,3	346,8	490,2	427,7
	2 + 2	148,6	93,8	132,7	77,9	213,6	158,8	294,5	239,7	335	280	375,4	320,6	456,3	401,5		
	1 + 1	93,8	54,7	171,8	132,7	252,7	213,6	333,6	294,5	374,1	335	414,5	375,4				
P40S	4 + 4	766,9	491,6					489,1	213,8	558,8	313,4	688,3	413	887,4	612,1	1086,6	811,3
	3 + 3	629,3	432,6			349	152,3	548,1	351,5	647,7	451,1	747,3	550,6	946,4	749,8	1145,6	948,9
	2 + 2	452,3	314,6	267,9	103,2	467	329,3	666,1	528,5	765,7	628,1	865,3	727,6	1064,4	926,8		
	1 + 1	275,3	177	405,5	307,2	604,6	506,3	803,8	705,5	903,4	805,1	1002,9	904,6				
P50S	4 + 4	1206	723,6					987,4	505	1166	683	1343,8	861,4	1700,2	1217,8	2056,7	1574,3
	3 + 3	827	516,8			837,6	527,5	1194	884	1372	1062	1550,5	1240,4	1907	1596,9	2263,4	1953,3
	2 + 2	585,8	344,6	653,5	412,3	1009,9	768,7	1366,4	1125,2	1545	1303	1722,8	1481,6	2079,3	1838,1	2435,7	2194,5
	1 + 1	344,6	206,7	791,3	653,5	1147,7	1010	1504,2	1366,4	1682	1545	1860,6	1722,8	2217,1	2079,3		
PA60S	6 + 6	2075	1383			861,5	169,9	1468	776,6	1772	1080	2074	1383	2682	1990	3288	2597
	5 + 5	1729	1153			1092	515,7	1699	1122	2002	1426	2305	1729	2912	2336	3519	2942
	4 + 4	1383	922	716	254,8	1322	861,5	1929	1468	2232	1772	2536	2075	3143	2682	3749	3288
	3 + 3	1037	692	946	600,6	1553	1207	2160	1814	2463	2117	2767	2421	3373	3027		
PA70S	2 + 2	692	462	1177	945,5	1784	1553	2390	2159	2694	2463	2997	2767				

POLYAMIDE PNEUMATIC ACTUATORS

TECHNICAL FEATURES

Rotation Angle and Torques

Polyamide actuators, 0° - 90° rotation angle to pilot ball, butterfly and plug valves.
Broad range of actuators, both Double Acting and Spring Return, from 17Nm to 165Nm at 6 bar.

LIGHT WEIGHT AND VERY RESISTANT TO CORROSION

Silicone free.

Manufactured in Polyamide + Glass Fiber offering best properties:

- High resistance to corrosion
- High mechanical strength
- Light weight

Threaded Inserts and Shaft

Stainless Steel Shaft and Threaded Inserts to guarantee the best resistance against corrosion and wearing:



ALL SHAFT AND INSERTS IN STAINLESS STEEL

Pressure

May be actuated with air or any nonaggressive fluid up to 8 bar pressure

Normal Working Temperature

-32°C to +90°C



Mounting Kits

Broad range of couplings for any kind of valve adaption.



Applications

Suitable for marine and underwater installations.
Designed to actuate plastic valves.
Mainly Industrial Applications: Food and Beverage, Automated Irrigation, Fishing Industry, etc...

Directives

Conformance to: ISO-5211, DIN-3337, VDI/VDE-3845, NAMUR.

Pneumatic connection according to NAMUR norm, in order to mount solenoid valves easily.

Prisma Pneumatic Actuators are manufactured under the requirements of PED 97-23-EC and ATEX 94-9-EC Directive.

ATEX EXII2GDT6 Certification



Elements of Regulation and Control

May be equipped with limit switches, solenoid valve, positioner and manual override by wheel or declutchable gearbox.



17Nm

165Nm

POLYAMIDE PNEUMATIC ACTUATORS

PP RANGE

THREADED INSERTS

Stainless Steel Threaded Inserts to guarantee the best resistance against corrosion and wearing.

SPRINGS

Concentric spring set.
Variable quantity (1 to 4 springs).

SHAFT

Shaft end according to VDI/VDE 3845 Norm (NAMUR).
Shaft made in Stainless Steel.

BODY AND CAPS

Made in Polyamide + Glass Fiber.

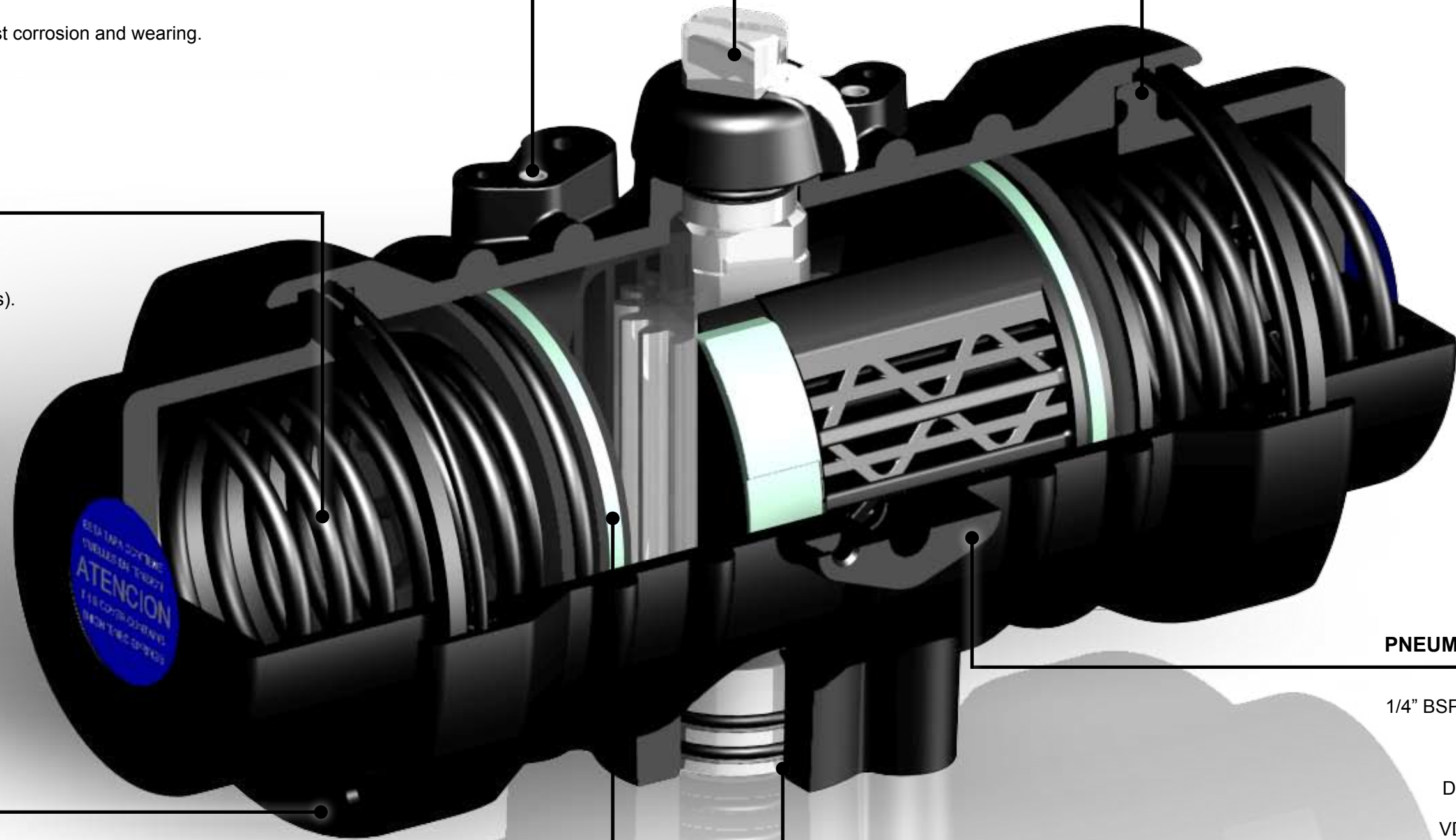

CAPS

Fixed by security ring protected against corrosion.

PISTONS

Wearing strips in pistons, allowing low friction and long life of the actuator.

VALVE FIXATION

ISO-5211 Norm for all models.

PNEUMATIC CONNECTION

1/4" BSP pneumatic connection to solenoid valve.
Dimensions according to VDI/VDE 3845 (NAMUR)

POLYAMIDE PNEUMATIC ACTUATORS

DISASSEMBLY AND MATERIALS

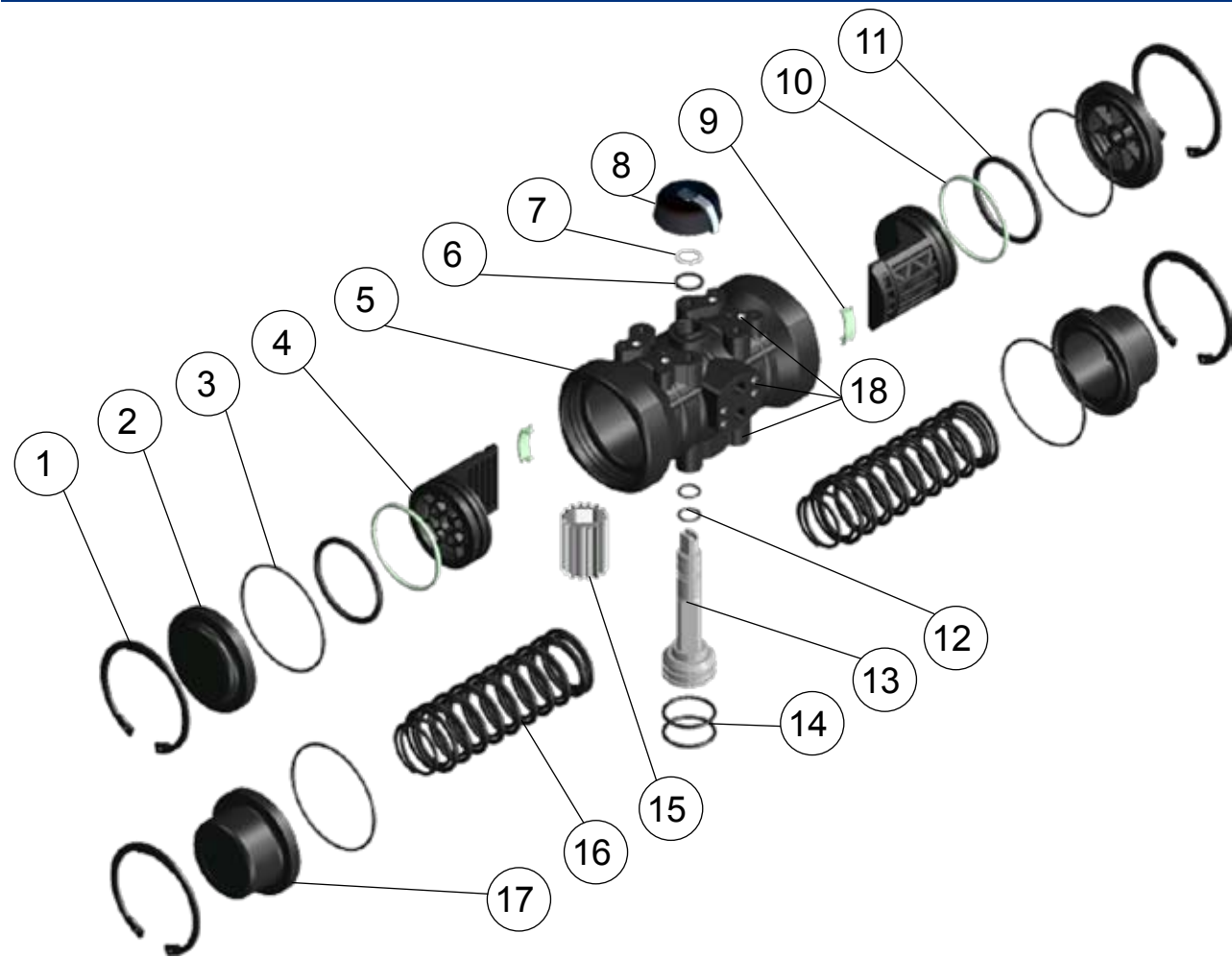

N°	DESCRIPTION	QUANTITY	MATERIAL	SURFACE FINISH
1	SPRING CLIP	2	STEEL	CATAPHORESIS COVERED
2	DOUBLE ACTING CAP	2	POLYAMIDE + GLASS FIBER	-
3	CAP O-RING	2	N.B.R.	-
4	PISTON	2	POLYARILAMIDE	-
5	CYLINDER	1	POLYAMIDE + GLASS FIBER	-
6	WASHER	1	POLYAMIDE 6	-
7	SPRING CLIP	1	STAINLESS STEEL	-
8	POSITION INDICATOR	1	POLYACETAL	-
9	PISTON GUIDE	2	POLYACETAL (Except PPW)	-
10	GUIDE RING	2	POLYACETAL	-
11	PISTON O-RING	2	N.B.R.	-
12	O-RING	2	N.B.R.	-
13	SHAFT	1	AISI-303 STAINLESS STEEL POLYAMIDE + S.S insert (PPW)	-
14	O-RING	2	N.B.R.	-
15	GEAR	1	ALUMINIUM ALLOY (PP10-PP20)	BALL BURNISHING
16	SPRING SET	0-8	DIN-17223-C	CATAPHORESIS COVERED
17	SPRING RETURN CAP	2	POLYAMIDE + GLASS FIBER	-
18	THREAD INSERTS	10	STAINLESS STEEL	-

PP DIMENSIONS

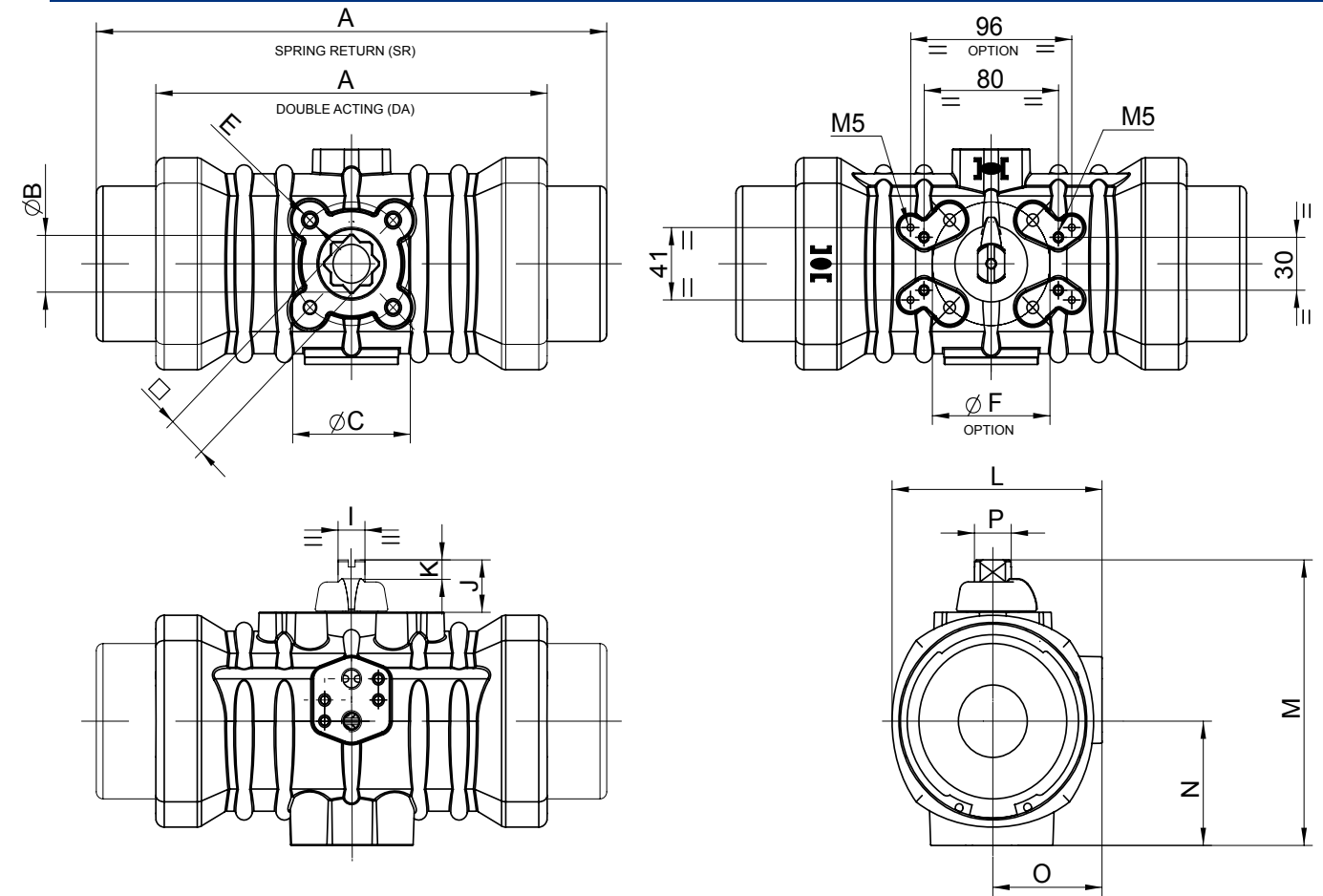

SHAFT DETAIL

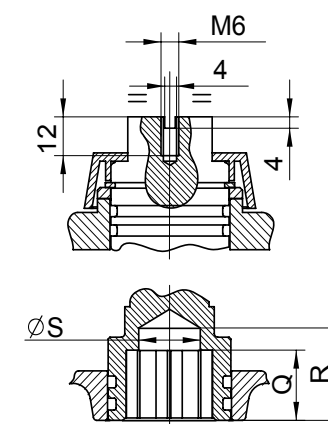

NAMUR PNEUMATIC CONNECTION

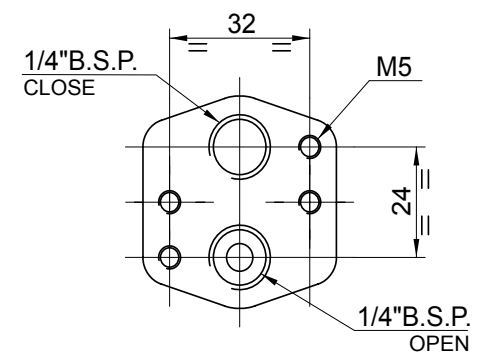

MODELS	DIMENSIONS (mm)																	
	A		□	B	C	E	F	I	J	K	L	M	N	O	P	Q	R	S
	DA	SR			ISO-5211		ISO-5211											
PPW - PPWS	107	142	11	14,3	φ42 F04	M5	-	8	20	7,5	68,5	85	31	37,5	9	13,5	17,8	10
PP00 - PP00S	125	155	20	26,2	φ50 F05	M6	φ50 F05	10	30	11	80	110	45	44	13,8	15	30	14,5
PP10 - PP10S	182	230	24	32,2	φ70 F07	M8	φ70 F07	10	30	11	102	128	50	53	13,8	15	30	15
PP20 - PP20S	233	304	24	32,2	φ70 F07	M8	φ70 F07	16	30	11	125	162	70,4	65	21,8	19	32	19

POLYAMIDE PNEUMATIC ACTUATORS

CYCLE TIME, WEIGHTS AND CAPACITY

MODELS		CYCLE TIME (sec.)				WEIGHTS (Kg)		CAPACITY (litre)			
		TO OPEN		TO CLOSE				TO OPEN		TO CLOSE	
DA	SR	DA	SR	DA	SR	DA	SR	DA	SR	DA	SR
PPW	PPWS	0,1	0,15	0,1	0,15	0,33	0,47	0,075	0,075	0,05	-
PP00	PP00S	0,15	0,2	0,15	0,2	0,76	1,03	0,15	0,15	0,1	-
PP10	PP10S	0,25	0,3	0,25	0,3	1,41	2,15	0,35	0,35	0,32	-
PP20	PP20S	0,4	0,5	0,4	0,5	2,94	4,95	0,8	0,8	0,7	-

DOUBLE ACTING AND SPRING RETURN ACTUATORS

- Double acting and spring return actuators with torques from 17Nm to 165Nm at 6 bar.
- May be actioned with air or any nonaggressive fluid up to 8 bar pressure.
- Suitable for marine and underwater installations.



DOUBLE ACTING



SPRING RETURN

OPERATING TORQUE

MODELS	DOUBLE ACTING (DA)						
	Air torque at indicated pressure (bar)						
	3	4	5	5,5	6	7	8
PPW	7,9	11,3	14,1	15,6	17	19,8	22,9
PP00	11,6	16,1	20,5	22,8	25	29,5	33,9
PP10	32,9	45,6	58,3	64,7	71	83,7	96,4
PP20	77,7	107	136,9	150,9	165,5	194,8	224

Units: Nm

MODELS	Spring Number	Spring Torques (Nm)	AIR TORQUE AT INDICATED PRESSURE (bar)														
			3		4		5		5,5		6		7		8		
			Initial	End	Initial	End	Initial	End	Initial	End	Initial	End	Initial	End	Initial	End	
PPWS	4 + 4	10,4	6,5					7,5	3,6	9,1	5,2	10,6	6,7	13,6	9,7	16,4	12,5
	3 + 3	9,3	5,8			5,2	1,8	8,2	4,8	9,8	6,3	11,3	7,8	14,3	10,9	17,1	13,7
	2 + 2	6,5	4,3	3,7	1,4	6,7	4,5	9,7	7,5	11,3	9,1	12,8	10,6	15,8	13,6		
	1 + 1	4,5	3	5	3,5	8	6,5	11,1	9,6	12,6	11,1	14,1	12,6				
PP00S	4 + 4	15,9	11,3					9,2	4,6	11,5	6,9	13,7	9,1	18,1	13,5	22,6	20,8
	3 + 3	13,1	10,3			5,8	3	10,3	7,4	12,5	9,7	14,7	11,9	19,2	16,3	23,6	20,8
	2 + 2	10,5	7,4	4,2	1,1	8,7	5,6	13,1	10,1	15,4	12,3	17,6	14,5	22,1	19		
	1 + 1	7	4,8	6,8	4,7	11,3	9,1	15,8	13,6	18	15,8	20,2	18				
PP10S	4 + 4	46,6	32,3					26	11,7	32,4	18,1	38,7	24,4	51,4	37,1	64,1	49,8
	3 + 3	40,4	28,6					29,7	17,9	36,1	24,3	42,4	30,6	55,1	43,3	67,8	56
	2 + 2	28	19,8			25,8	17,7	38,5	30,4	44,9	36,7	51,2	43,1	63,9	55,8		
	1 + 1	18,7	13	19,9	14,2	32,6	26,9	45,4	39,6	51,7	46	58,1	52,3				
PP20S	4 + 4	103,3	64,2					72,1	33	86,7	47,6	101,3	62,2	130,6	91,5	159,8	120,7
	3 + 3	92,2	55,9			51,2	14,9	80,4	44,1	95	58,7	109,6	73,3	139	102,6	168,2	131,9
	2 + 2	67	39,1	38,6	10,7	67,9	40	97,2	69,3	111,8	83,9	126,4	98,5	155,7	127,8		
	1 + 1	41,9	25,1	52,6	35,8	81,9	65,2	111,2	94,4	125,8	109	140,4	123,6				

Units: Nm

STAINLESS STEEL PNEUMATIC ACTUATORS

TECHNICAL FEATURES

Rotation Angle and Torques

Stainless Steel actuators, 0°-90° rotation angle to pilot ball, butterfly and plug valves.

Broad range of actuators, both in Double Acting and Spring Return, from 25 to 470Nm at 6 bar.

HIGHLY CORROSIVE ENVIRONMENTS

Specially designed for Highly Corrosive environments. Silicone free.

Stroke Adjustments

External Stroke Adjustments (except PI00) to regulate opening (+85° to +92°) and closing (-2° to +5°) of the valve, both in double acting and spring return.

Predominantly used in butterfly valves, to adjust closing of the disc.

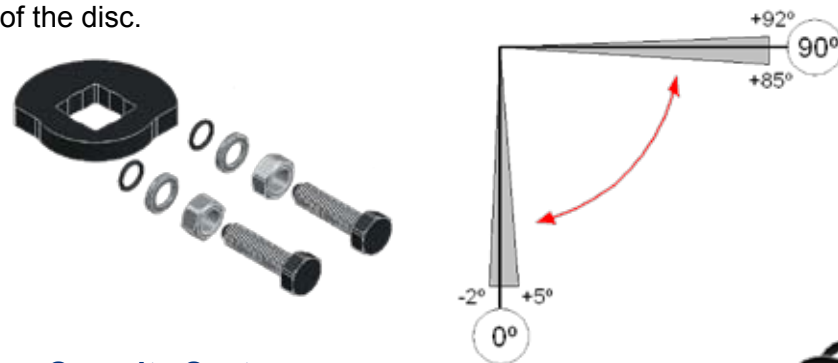

Spring Security System

Spring security System, making manipulation and mounting easy and safe.

All components are protected against corrosion.

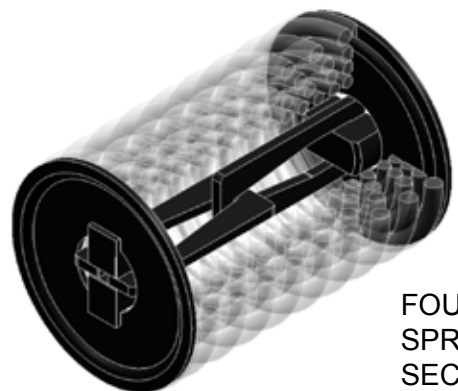

FOUR PRELOADED SPRING CARTRIDGE WITH SECURITY SYSTEM.

Pressure

May be actuated with air or any nonaggressive fluid up to 8 bar pressure.

Normal Working Temperature

-32°C to +90°C (-50°C to +150°C, on demand).



Elements of Regulation and Control

May be equipped with limit switches, solenoid valve, positioner and override by wheel or declutchable gearbox.



Directives

Conformance to: ISO-5211, DIN-3337, VDI/VDE-3845 specifications for easy mounting of most valves.

Pneumatic connection according to NAMUR norm, in order to mount solenoid valves easily.

Prisma Pneumatic Actuators are manufactured under the requirements of PED 97-23-EC, ATEX 94-9-EC.

Directive and SIL-2.

ATEX EXII2GDT6 Certification.

Mounting Kits

Broad range of couplings (brackets and drive adapters) for any kind of valve adaptation.



Applications

Suitable for underwater and marine installations. For highly corrosive environments and off-shore plant applications.

25Nm

470Nm

STAINLESS STEEL PNEUMATIC ACTUATORS

PI RANGE

SHAFT

Shaft end according to
VDI/VDE 3845 Norm (NAMUR)
Material: Stainless Steel.

PNEUMATIC CONNECTION

1/4" BSP pneumatic connection
to solenoid valve.
Dimensions according to
VDI/VDE 3845 (NAMUR)

STROKE ADJUSTMENTS

Standard across the range
except for PI00.
To regulate the actuator
opening and closing
(+2° / -5° to regulation).

SPRINGS

Preloaded springs with
security system.
Easy to mount and to change
number of springs

VALVE FIXATION

ISO-5211 Norm for all models.

PISTONS

Wearing strips in pistons,
allowing low friction and
long life of the actuator.

CAPS

Fitted by Stainless Steel bolts.
Larger caps for spring
return actuator models.

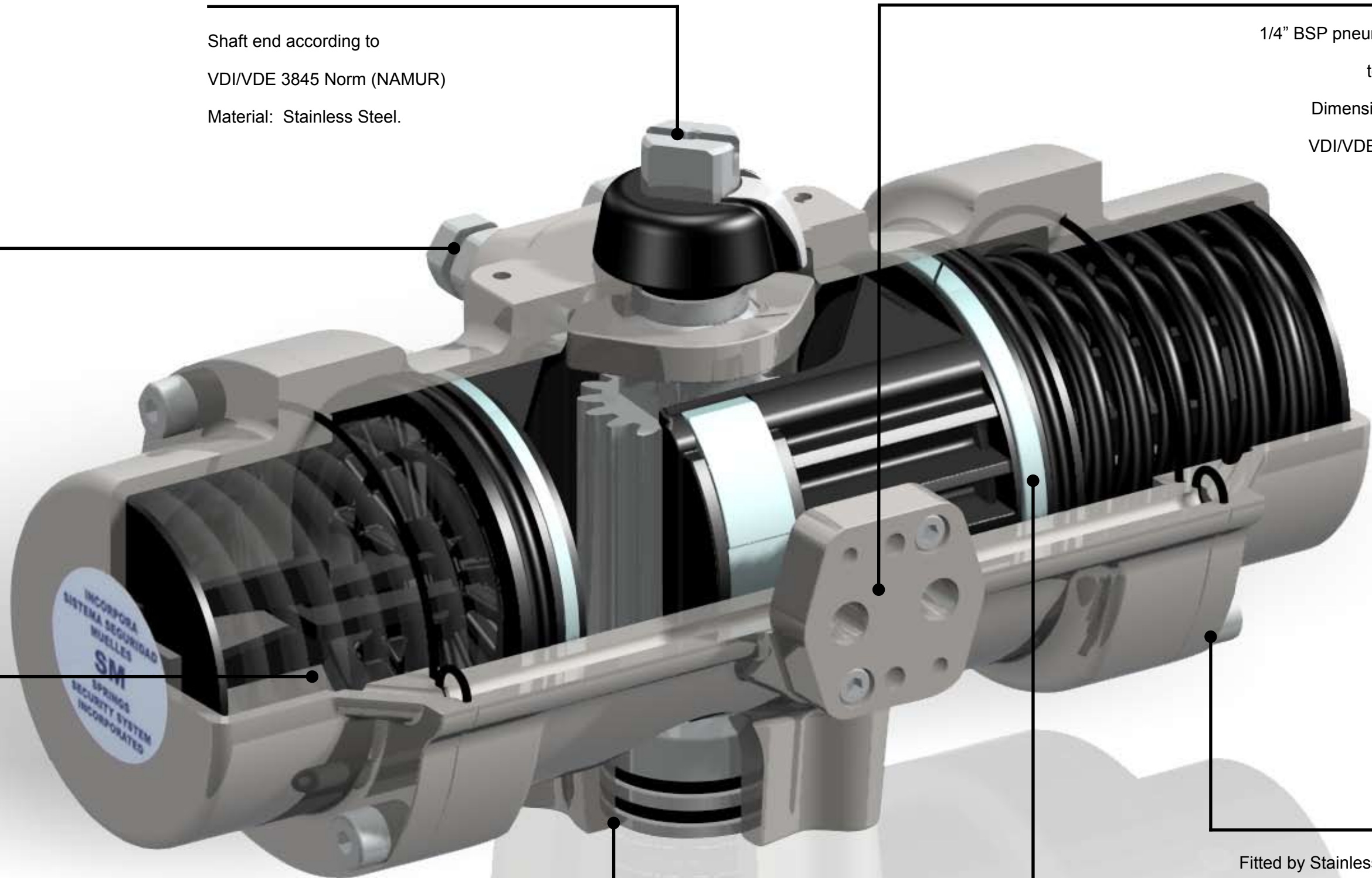

STAINLESS STEEL PNEUMATIC ACTUATORS

DISASSEMBLY AND MATERIALS

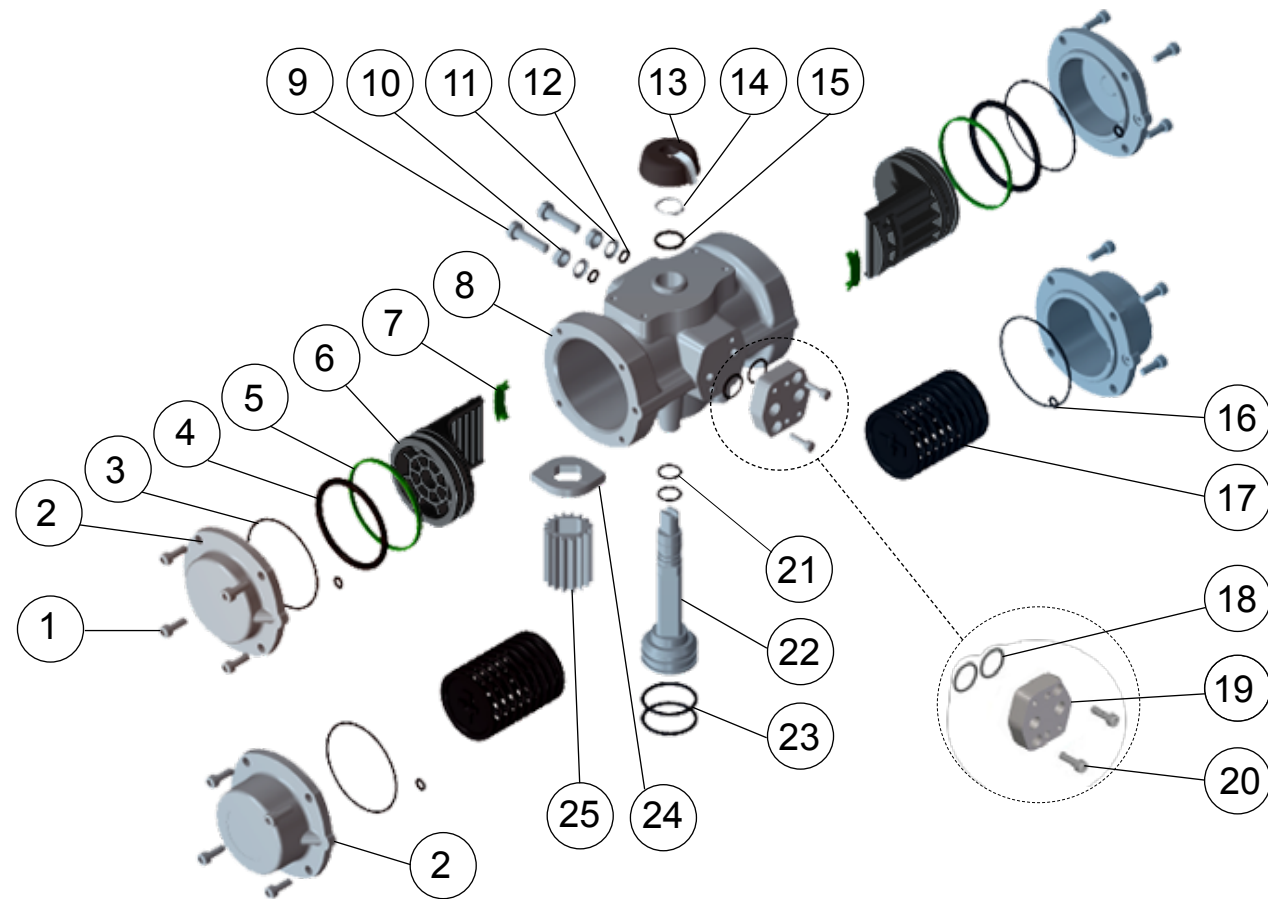

N°	DESCRIPTION	QUANTITY	MATERIAL	SURFACE FINISH
1	CAP ALLEN SCREW	8 - 12	AISI-316 STAINLESS STEEL	CATAPHORESIS COVERED
2	CAPS	2	CF8M STAINLESS STEEL	-
3	CAP O-RING	2	N.B.R.	-
4	PISTON O-RING	2	N.B.R.	-
5	GUIDE RING	2	POLYACETAL	-
6	PISTON	2	POLYARILAMIDE + GF	-
7	PISTON GUIDE	2	POLYACETAL	-
8	CYLINDER	1	CF8M STAINLESS STEEL	-
9	BOLT	2	AISI-316 STAINLESS STEEL	-
10	NUT	2	AISI-316 STAINLESS STEEL	-
11	BUSHING	2	AISI-316 STAINLESS STEEL	-
12	O-RING	2	N.B.R.	-
13	POSITION INDICATOR	1	POLYAMIDE	-
14	SPRING CLIP	1	STAINLESS STEEL	-
15	BUSHING	1	POLYAMIDE 6	-
16	CAP O-RING	2	N.B.R.	-
17	PRELOADED SPRINGS	0-8	DIN-17223-C	CATAPHORESIS COVERED
18	CAP O-RING	2	N.B.R.	-
19	PNEUMATIC CONNECTON PLATE	1	CF8M STAINLESS STEEL	-
20	PLATE ALLEN SCREW	2	AISI-316 STAINLESS STEEL	-
21	SHAFT O-RING	2	N.B.R.	-
22	SHAFT	1	AISI-303 STAINLESS STEEL	OPTION: AISI-316 STAINLESS STEEL
23	SHAFT O-RING	2	N.B.R.	-
24	CAM	1	CF8 STAINLESS STEEL	-
25	GEAR	1	ALUMINIUM ALLOY	CATAPHORESIS COVERED + BURNISH

PI DIMENSIONS

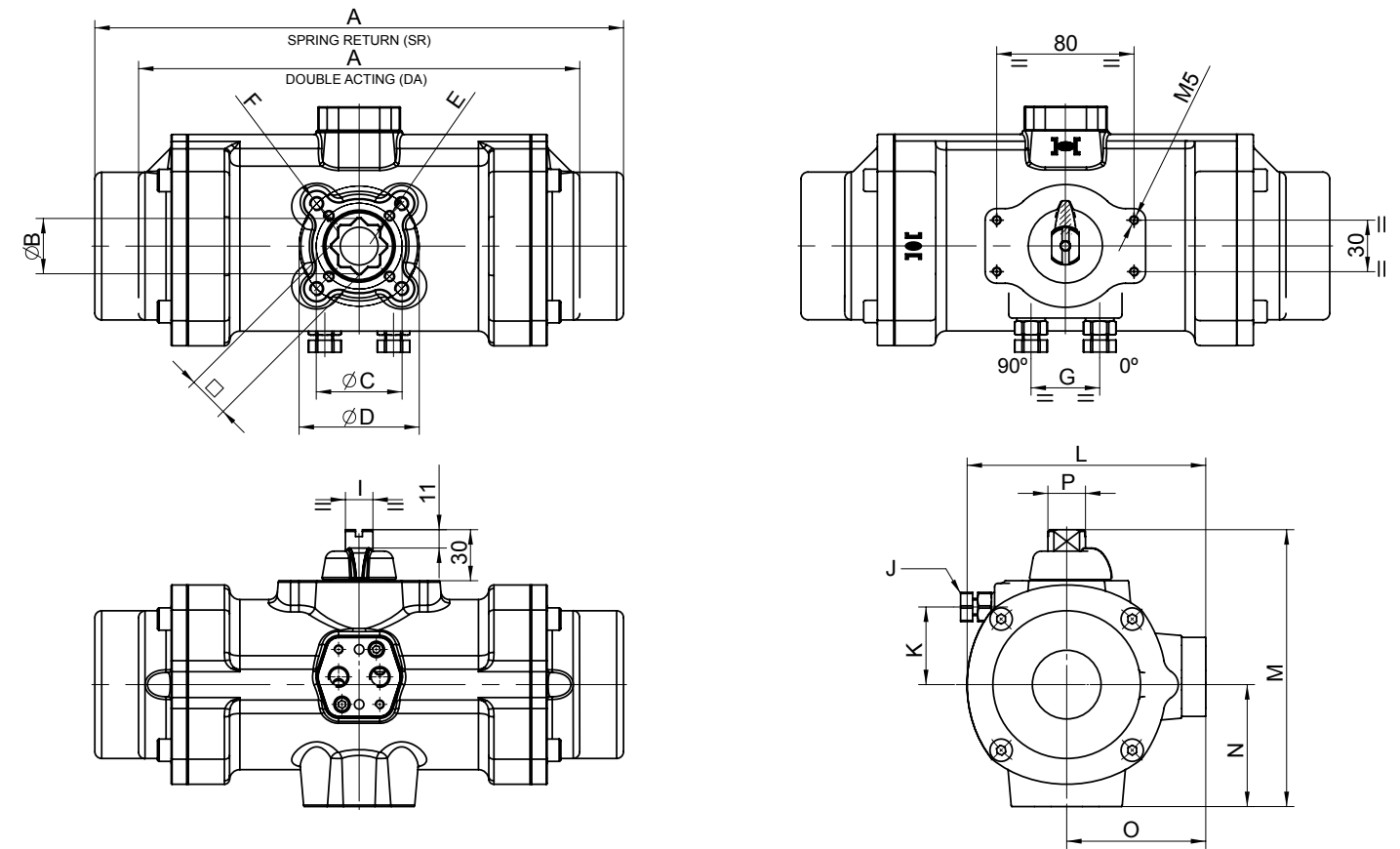

SHAFT DETAIL

NAMUR PNEUMATIC CONNECTION

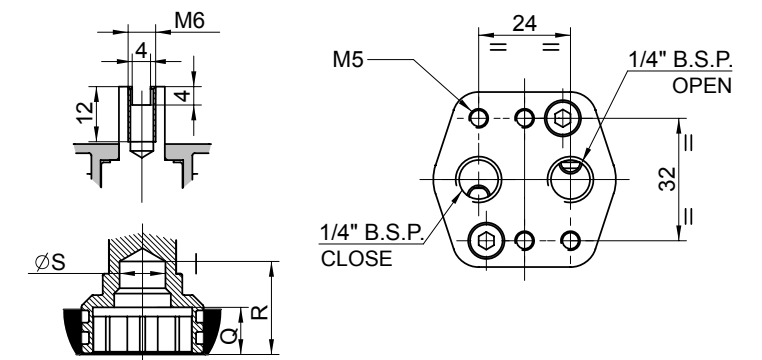

MODELS	DIMENSIONS (mm)																					
	A		□	B	C		E	D		F	G	I	J	K	L	M	N	O	P	Q	R	S
	DA	SR			ISO-5211	ISO-5211																
PI00 - PI00S	139	160	20	26,2	φ50 F05	M6	-	-	-	-	10	-	-	91	111	45	55	13,8	15	30	14,5	
PI10 - PI10S	198	231	24	32,2	φ50 F05	M6	φ70 F07	M8	32	10	M8	33	112,5	126	49,7	65,5	13,8	15	30	15		
PI20 - PI20S	257	308	24	32,2	φ50 F05	M6	φ70 F07	M8	40	16	M10	45,2	139	160	71	81	21,8	19	32	22		
PI30 - PI30S	350	478	27	36,5	φ70 F07	M8	φ102 F10	M10	46	16	M12	58	185,5	211	96	103	21,8	30	42	27		

STAINLESS STEEL PNEUMATIC ACTUATORS

CYCLE TIME, WEIGHTS AND CAPACITY

MODELS		CYCLE TIME (sec.)				WEIGHTS (Kg)		CAPACITY (litre)			
		TO OPEN		TO CLOSE				TO OPEN		TO CLOSE	
DA	SR	DA	SR	DA	SR	DA	SR	DA	SR	DA	SR
PI00	PI00S	0,15	0,2	0,15	0,2	2,2	2,6	0,15	0,15	0,1	-
PI10	PI10S	0,25	0,3	0,25	0,3	4,7	5,6	0,35	0,35	0,32	-
PI20	PI20S	0,4	0,5	0,4	0,5	5,9	9,9	0,8	0,8	0,7	-
PI30	PI30S	0,6	1,2	0,6	1,2	17,9	25,4	2,05	2,05	1,9	-

DOUBLE ACTING AND SPRING RETURN ACTUATORS

- Double acting and spring return actuators with torques from 25Nm to 470Nm at 6 bar.
- May be actioned with air or any nonaggressive fluid up to 8 bar pressure. For highly corrosive environments and off-shore plant applications.



DOUBLE ACTING

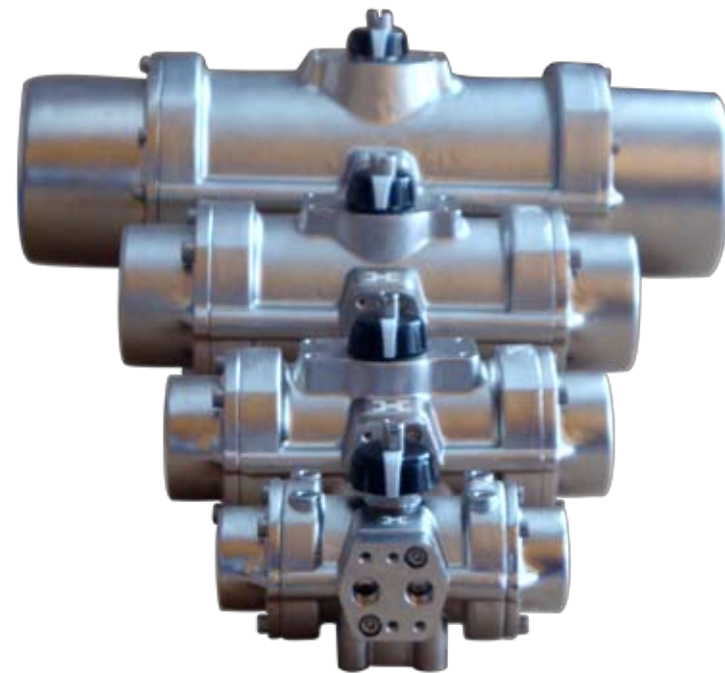

SPRING RETURN

OPERATING TORQUE

MODELS		DOUBLE ACTING (DA)						
		Air torque at indicated pressure (bar)						
		3	4	5	5,5	6	7	8
PI00		11,6	16,1	20,5	22,8	25	29,5	33,9
PI10		32,9	45,6	58,3	64,7	71	83,7	96,4
PI20		77,7	107	136,3	150,9	165,5	194,8	224
PI30		226,5	307,4	388,3	428,8	469,2	550,1	631

Units: Nm

MODELS		Spring Number	Spring Torques (Nm)		SPRING RETURN (SR)												
					Air torque at indicated pressure (bar)												
					3		4		5		5,5		6		7		8
		Initial	End	Initial	End	Initial	End	Initial	End	Initial	End	Initial	End	Initial	End		
PI00S	4 + 4	15,9	11,3					9,2	4,6	11,5	6,9	13,7	9,1	18,1	13,5	22,6	18
	3 + 3	13,1	10,3			5,8	3	10,3	7,4	12,5	9,7	14,7	11,9	19,2	16,3	23,6	20,8
	2 + 2	10,5	7,4	4,2	1,1	8,7	5,6	13,1	10,1	15,4	12,3	17,6	14,5	22,1	19		
	1 + 1	7	4,8	6,8	4,7	11,3	9,1	15,8	13,6	18	15,8	20,2	18				
PI10S	4 + 4	46,6	32,3					26	11,7	32,4	18,1	38,7	24,4	51,4	37,1	64,1	49,8
	3 + 3	40,4	28,6					29,7	17,9	36,1	24,3	42,4	30,6	55,1	43,3	67,8	56
	2 + 2	28	19,8			25,8	17,7	38,5	30,4	44,9	36,7	51,2	43,1	63,9	55,8		
	1 + 1	18,7	13	19,9	14,2	32,6	26,9	45,4	39,6	51,7	46	58,1	52,3				
PI20S	4 + 4	103,3	64,2					72,1	33	86,7	47,6	101,3	62,2	130,6	91,5	159,8	120,7
	3 + 3	92,2	55,9			51,2	14,9	80,4	44,1	95	58,7	109,6	73,3	139	102,6	168,2	131,9
	2 + 2	67	39,1	38,6	10,7	67,9	40	97,2	69,3	111,8	83,9	126,4	98,5	155,7	127,8		
	1 + 1	41,9	25,1	52,6	35,8	81,9	65,2	111,2	94,4	125,8	109	140,4	123,6				
PI30S	4 + 4	273,7	179,9			127,5	33,7	208,4	114,6	248,9	155,1	289,3	195,5	370,2	276,4	451,1	357,3
	3 + 3	203,3	140,8	85,8	23,2	166,6	104,1	247,5	185	288	225,5	328,4	265,9	409,3	346,8	490,2	427,7
	2 + 2	148,6	93,8	132,7	77,9	213,6	158,8	294,5	239,7	335	280,2	375,4	320,6	456,3	401,5		
	1 + 1	93,8	54,7	171,8	132,7	252,7	213,6	333,6	294,5	374,1	335	414,5	375,4				

Units: Nm

SPECIAL ACTUATORS

180° ROTATION ACTUATORS

Pneumatic actuators in double acting and spring return with 180° rotation covering a torque range from 36Nm to 230Nm.

Application for 3 way valves.

PAG10 - PAG10S

PAG20 - PAG20S

PG30 - PG30S



180° ACTUATOR CYCLE TIME, WEIGHTS AND CAPACITY:

MODELS		CYCLE TIME (sec.)				WEIGHTS (Kg)		CAPACITY (litre)			
		TO OPEN		TO CLOSE				TO OPEN		TO CLOSE	
DA	SR	DA	SR	DA	SR	DA	SR	DA	SR	DA	SR
PAG10	PAG10S	0,25	0,3	0,25	0,3	3,1	3,5	0,35	0,35	0,45	-
PAG20	PAG20S	0,4	0,5	0,4	0,5	5,2	6,7	0,8	0,8	1,15	-
PG30	PG30S	0,3	1,2	0,6	1,2	9,65	16,45	2,05	1,9	2,05	-

180° ACTUATOR TORQUES:

DOUBLE ACTING (DA)							
MODELS	Air torque at indicated pressure (bar)						
	3	4	5	5,5	6	7	8
PAG10	16,5	22,8	29,2	33	36	41,9	48,2
PAG20	38,9	53,5	68,2	75,5	82,8	97,4	112
PG30	111,5	151,3	191,2	211,1	231	270,8	310,6

SPRING RETURN (SR)																	
MODELS	Springs Number	Spring Torques (Nm)		Air torque at indicated pressure (bar)													
				3		4		5		5,5		6		7		8	
		Initial	End	Initial	End	Initial	End	Initial	End	Initial	End	Initial	End	Initial	End	Initial	End
PAG10S	6 + 6	22,8	15,4					13,8	6,4	17,1	9,7	20,1	12,7	26,5	19,1	32,8	25,4
	5 + 5	19	12,9					16,3	10,2	19,7	13,5	22,7	16,5	29	22,9	35,4	29,2
	4 + 4	15,2	10,3			12,6	7,6	18,9	14	22,3	17,3	25,3	20,3	31,6	26,7	38	33
	3 + 3	11,4	7,7	8,8	5,1	15,1	11,4	21,5	17,8	24,8	21,1	27,8	24,1	34,2	30,5		
	2 + 2	7,6	5,2	11,3	8,9	17,7	15,2	24	21,6	27,4	24,9	30,4	27,9				
PAG20S	6 + 6	52,3	32,9					35,3	15,9	42,6	23,2	49,9	30,5	64,5	45,1	79,1	59,7
	5 + 5	43,6	27,4			26,1	9,9	40,8	24,6	48,1	31,9	55,4	39,2	70	53,8	84,6	68,4
	4 + 4	34,9	21,9	17	4	31,6	18,6	46,3	33,3	53,6	40,6	60,9	47,9	75,5	62,5	90,1	77,1
	3 + 3	26,1	16,6	22,3	12,8	36,9	27,4	51,6	42,1	58,9	49,4	66,2	56,7	80,8	71,3		
	2 + 2	17,4	10,9	28	21,5	42,6	36,1	57,3	50,8	64,6	58,1	71,9	65,4				
PG30S	4 + 4	134,7	88,6			62,8	16,6	102,6	56,4	122,5	76,3	142,4	96,2	182,3	136,1	122,1	175,9
	3 + 3	100,1	69,3	42,2	11,4	82	51,2	121,8	91,1	141,8	110	161,7	130,9	201,5	170,7	241,3	210,6
	2 + 2	73,2	46,2	65,3	38,4	105,2	78,2	145	118	164,9	138	184,8	157,8	224,6	197,7		
	1 + 1	46,2	26,9	84,6	65,3	124,4	105	164,2	145	184,2	165						

Units: Nm

HIGH AND LOW TEMPERATURE

HIGH TEMPERATURE

For preferential application in fire-fighting systems.

Temperatures up to +265°C

Caps with allen screws.

LOW TEMPERATURE

With low temperature o-rings for applications on cryogenic sector.

Working temperature to -50°C.



FAIL OPEN ACTUATORS

Used in spring return actuators to assure that the valve remains open if there is a failure in the air pressure supply.

Used when it is necessary to assure the fluid is passing through the valve in emergency cases.

REVERSE ACTUATORS

Actuators with opposite direction of rotation.

Applied in valves with end limits, dampers, etc...

SHAFT MOUNTED AT 90°

Actuators to be mounted across the pipe keeping open-close indication.

STAINLESS STEEL OPTIONS

Shaft Options:

- Aluminium Actuators - Shaft in Aisi-303 Stainless Steel
- Stainless Steel Actuators - PI00-PI10-PI20 Option: Aisi-316
- Polyamide Actuators - PP00-PP10-PP20 Option: Aisi-316

HEAVY DUTY PNEUMATIC ACTUATORS

TECHNICAL FEATURES

- High Torque actuators to mount on to ball, butterfly and plug valves.
- Wide range of Double Acting and Spring Return actuators up to 65.000Nm at 6 bar.
- Working temperature: -20°C to +80°C.

- Position Indicator and Stroke Adjustments allowing the regulation of valve opening and closing, with $\pm 5^\circ$ range on both double acting and spring return.

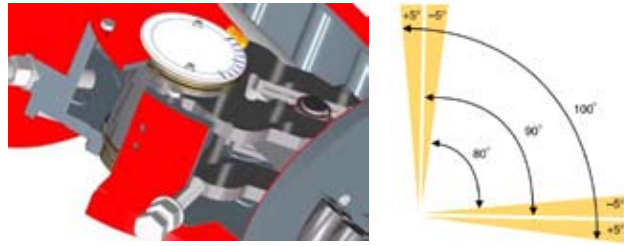

- Can be equipped with limit switches, solenoid valve and manual override.
- Spring Security System as standard. All components are protected against corrosion.



- PD pneumatic actuator range can pilot and regulate 90° rotation valves with torques up to 65.000 Nm in double acting and spring return function.

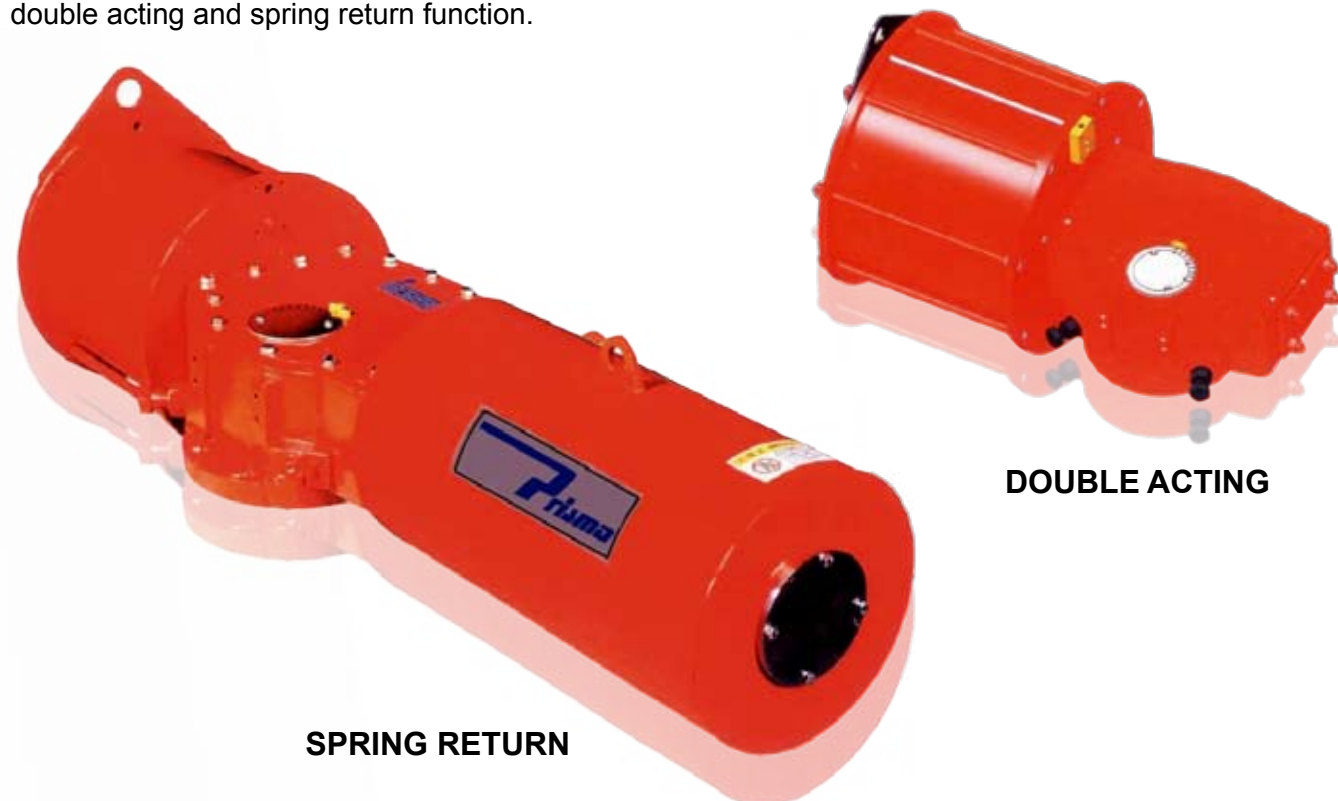

DISASSEMBLY AND MATERIALS

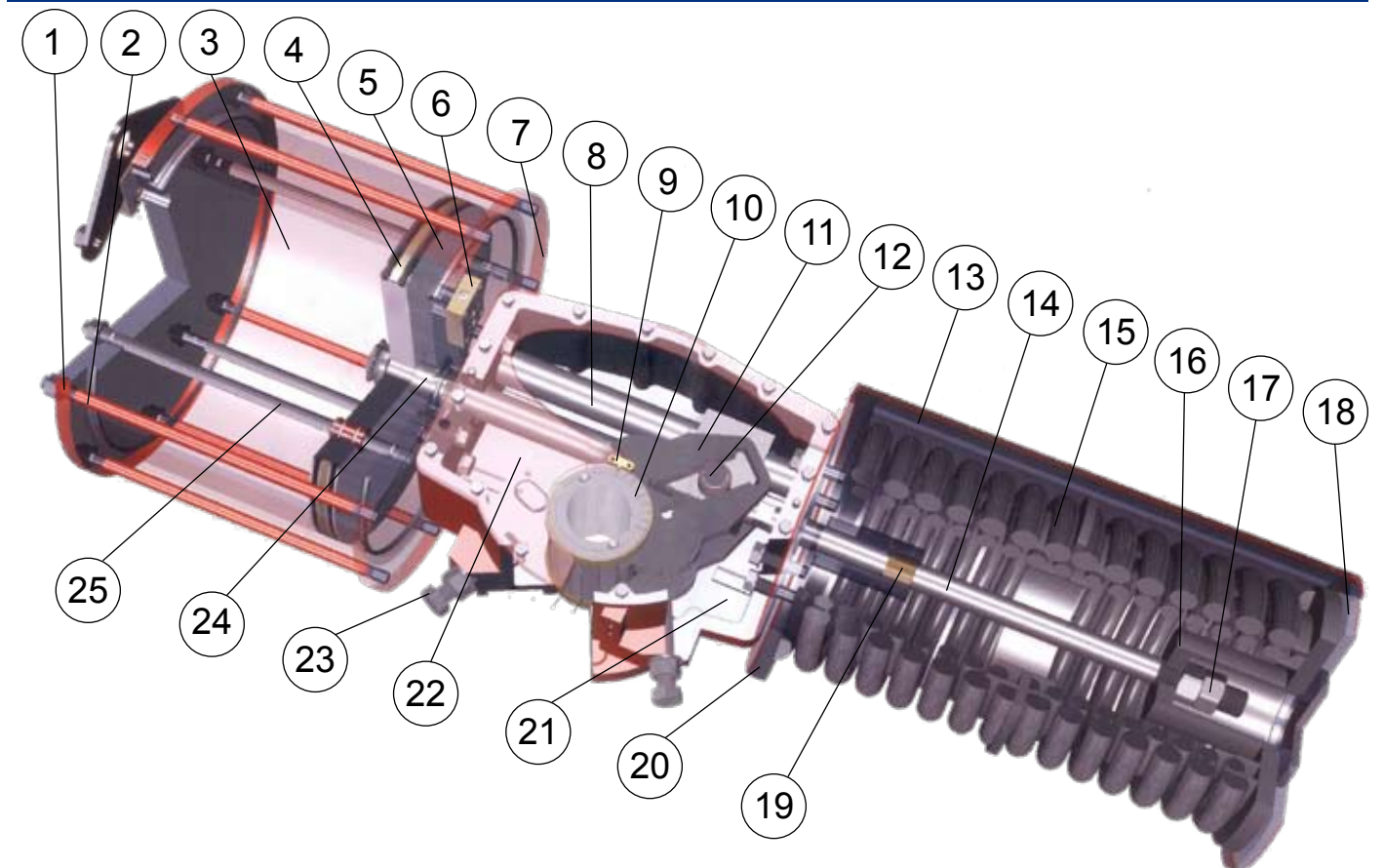

N°	DESCRIPTION	MATERIAL	REMARKS
1	CYLINDER END COVER	ALLOY STEEL	MOLYKOTE
2	TIE BOLT	ALLOY STEEL	-
3	CYLINDER	ALLOY STEEL	HARD Cr - PLATED
4	BACK-UP-RING	P.T.F.E	-
5	PISTON	ALLOY STEEL	MOLYKOTE
6	PNEUMATIC CONNECTION PLATE	ALM	-
7	CYLINDER FRONT COVER	ALLOY STEEL	MOLYKOTE
8	GUIDE BAR	ALLOY STEEL	HARD Cr - PLATED
9	POSITION NEEDLE	ALLOY STEEL	-
10	POSITION INDICATOR	STAINLESS STEEL	-
11	SLIDE BEARING	ALLOY STEEL	MOLYKOTE
12	SLIDE PIN	ALLOY STEEL	-
13	SPRING CASE	ALLOY STEEL	-
14	SPRING ROD	ALLOY STEEL	-
15	SPRING	ALLOY STEEL	-
16	SPRING RETAINER	ALLOY STEEL	-
17	ROD ADJUST NUT	ALLOY STEEL	-
18	CAP BOLT	ALLOY STEEL	-
19	SPRING ROD GUIDE BUSHING	ENGINEERING PLASTIC	-
20	SPRING CASE FRONT COVER	ALLOY STEEL	-
21	HOUSING	DUCTIL IRON	-
22	HOUSING COVER	ALLOY STEEL	-
23	STROKE ADJUSTMENTS	ALLOY STEEL	HIGH - TENSION
24	PISTON ROD	ALLOY STEEL	-
25	PISTON GUIDE BAR	ALLOY STEEL	-

HEAVY DUTY PNEUMATIC ACTUATORS

PD RANGE

SECURITY PISTON GUIDES

Actuators specially designed to guarantee the lowest friction between internal pieces.

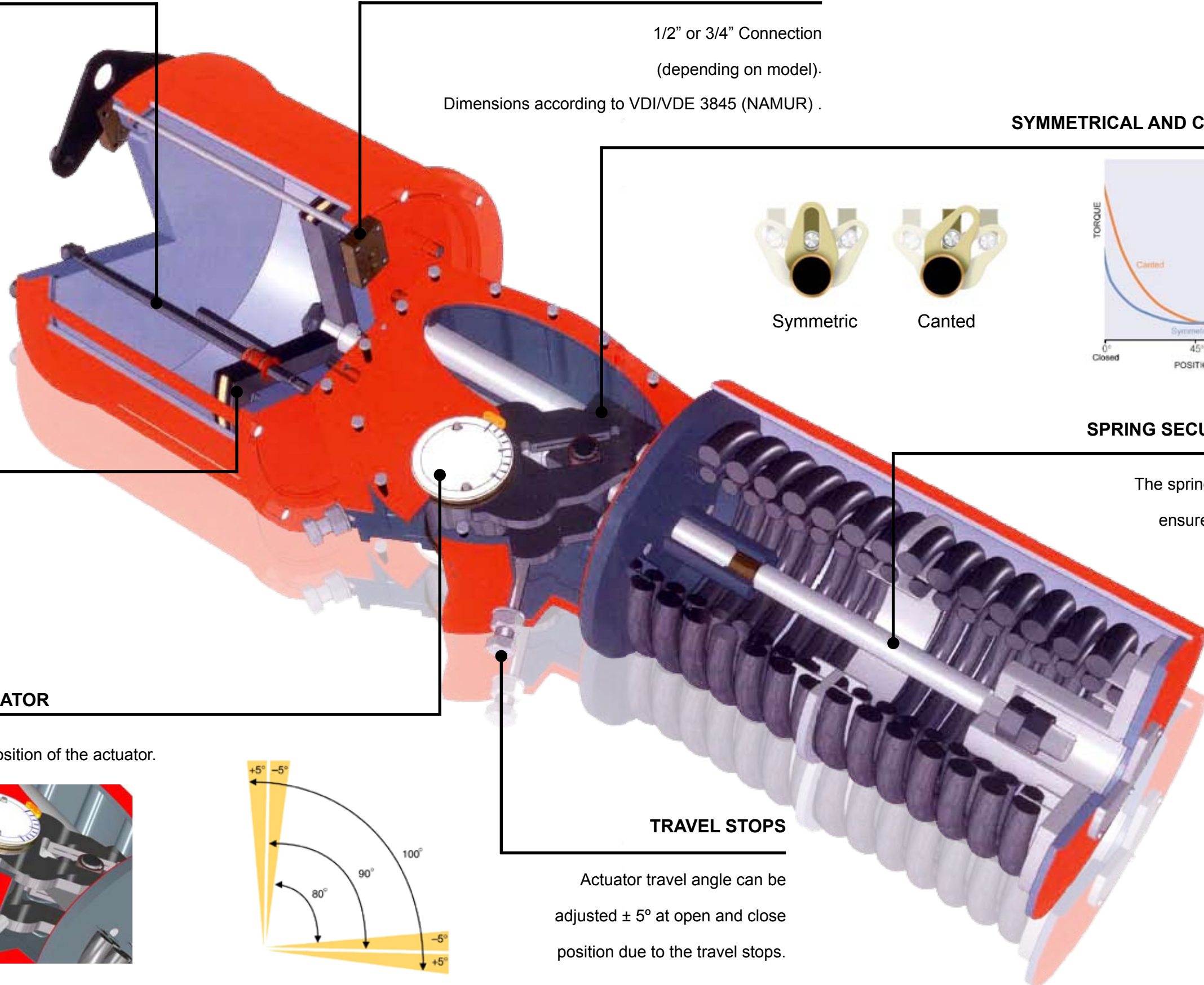

SOLENOID CONNECTION FLANGE

1/2" or 3/4" Connection
(depending on model).
Dimensions according to VDI/VDE 3845 (NAMUR).

SYMMETRICAL AND CANTED TYPES

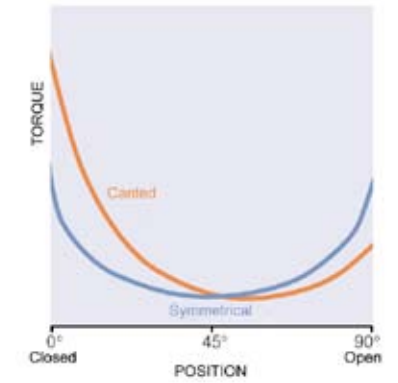
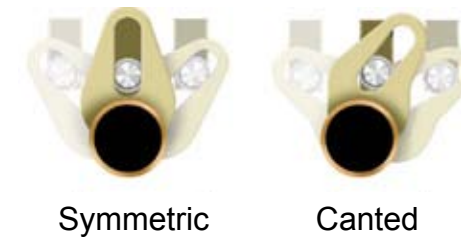

PISTON GUIDE RING

High quality ring preventing any leakage.

POSITION INDICATOR

Clearly indicates position of the actuator.

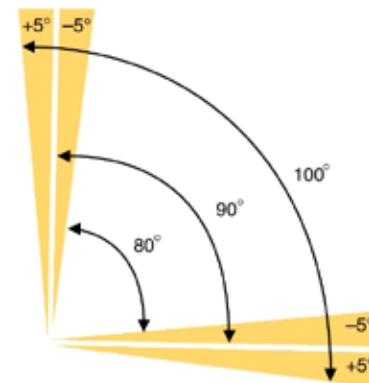
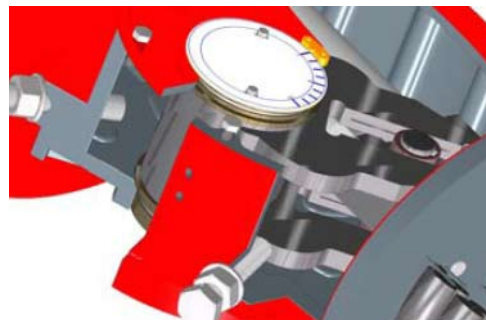

TRAVEL STOPS

Actuator travel angle can be adjusted $\pm 5^\circ$ at open and close position due to the travel stops.

SPRING SECURITY SYSTEM

The spring security system ensures safe operation.

HEAVY DUTY PNEUMATIC ACTUATORS

PD DIMENSIONS

DOUBLE ACTING

SPRING RETURN

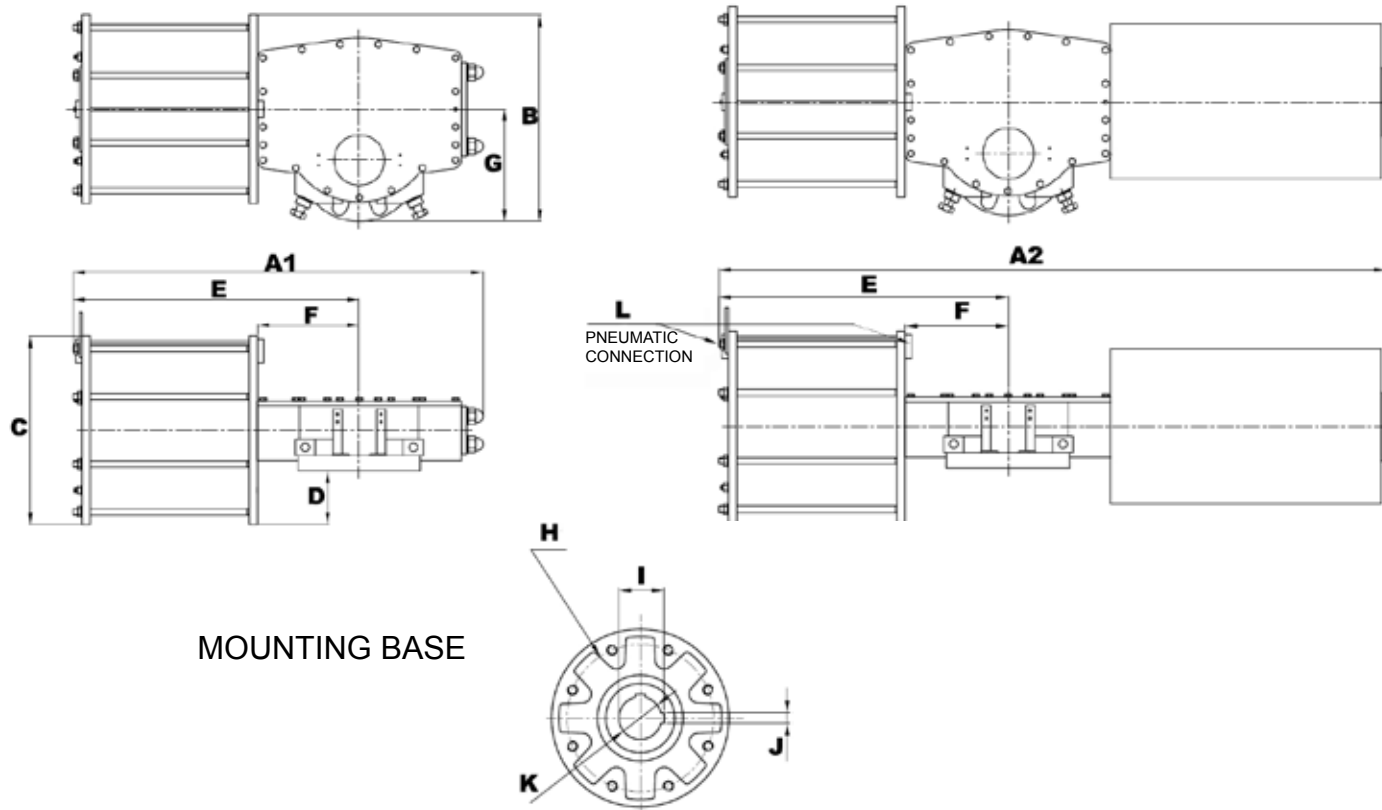

MOUNTING BASE

MODELS	DIMENSIONS (mm)																
	A1	A2	B	C	D	E	F	G	H			I	J	K		L	
		5,6 Bar							φ	N° holes	Thread/Depth			φ	DEPTH		
PD 100 - 335	888	1465	455	410	105	623	215	150	254	F25	8	M16 / 24	80	20	75	171	1/2" NPT
PD 100 - 385	888	1465	481	461	131	623	215	150	254	F25	8	M16 / 24	80	20	75	171	1/2" NPT
PD 100 - 435	888	1468	506	512	156	623	215	150	254	F25	8	M16 / 24	80	20	75	171	1/2" NPT
PD 130 - 435	1098	1807	566	512	144	776	272	180	298	F30	8	M20 / 29	95.4	22	90	191	3/4" NPT
PD 130 - 485	1098	1807	591	562	169	776	272	180	298	F30	8	M20 / 29	95.4	22	90	191	3/4" NPT
PD 130 - 535	1098	1810	622	624	200	776	272	180	298	F30	8	M20 / 29	95.4	22	90	191	3/4" NPT
PD 160 - 535	1301	2174	682	624	172	920	321	210	356	F35	8	M30 / 43	117.4	32	110	235	3/4" NPT
PD 160 - 585	1301	2177	708	675	198	920	321	210	356	F35	8	M30 / 43	117.4	32	110	235	3/4" NPT
PD 160 - 635	1301	2177	734	728	224	920	321	210	356	F35	8	M30 / 43	117.4	32	110	235	3/4" NPT
PD 200 - 635	1582	2576	810	739	211	1114	400	240	406	F40	8	M36 / 50	137.4	32	130	265	3/4" NPT
PD 200 - 685	1582	2578	835	789	236	1114	400	240	406	F40	8	M36 / 50	137.4	32	130	265	3/4" NPT
PD 200 - 735	1582	2583	863	845	263	1114	400	240	406	F40	8	M36 / 50	137.4	32	130	265	3/4" NPT

OPERATING TORQUE

DOUBLE ACTING (DA)

MODELS	5.6 BAR		
	0°	R	90°
PD 100 - 335 D	6.767	4.193	6.628
PD 100 - 385 D	8.938	5.538	8.753
PD 100 - 435 D	11.410	7.070	11.175
PD 130 - 435 D	14.833	9.191	14.528
PD 130 - 485 D	18.439	11.425	18.059
PD 130 - 535 D	22.437	13.903	21.975
PD 160 - 535 D	27.614	17.111	27.045
PD 160 - 585 D	33.017	20.459	32.336
PD 160 - 635 D	38.902	24.105	38.100
PD 200 - 635 D	48.628	30.132	47.625
PD 200 - 685 D	56.587	35.064	55.421
PD 200 - 735 D	65.150	40.369	63.806

SPRING RETURN (SR)

MODELS	Spring Torques (Nm)			Torque at Indicated Pressure		
				5.6 BAR		
	Initial	R	End	Initial	R	End
PD 100 - 335 S6	4.189	2.120	2.566	4.201	2.073	2.439
PD 100 - 385 S6	5.713	2.811	3.241	5.697	2.727	3.040
PD 100 - 435 S6	7.223	3.554	4.097	7.313	3.516	3.952
PD 130 - 435 S6	9.395	4.656	5.436	9.398	4.535	5.133
PD 130 - 485 S6	11.876	5.769	6.496	11.943	5.656	6.184
PD 130 - 535 S6	15.053	7.313	8.234	14.203	6.590	6.921
PD 160 - 535 S6	17.482	8.701	10.234	17.380	8.410	9.562
PD 160 - 585 S6	20.761	10.333	12.154	20.863	10.125	11.575
PD 160 - 635 S6	24.013	11.952	14.057	24.845	12.154	14.087
PD 200 - 635 S6	29.826	14.723	17.068	31.560	15.409	17.799
PD 200 - 685 S6	36.082	17.811	20.647	35.940	17.253	19.339
PD 200 - 735 S6	43.023	21.171	24.405	40.745	19.198	20.748

Units: Nm

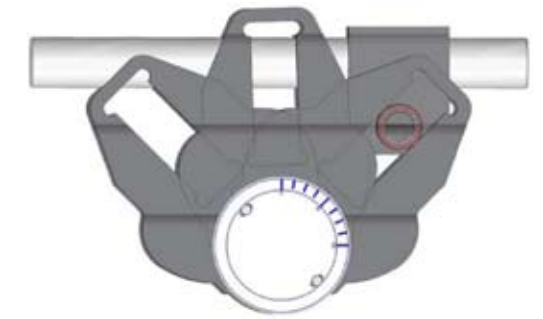

SYMMETRIC

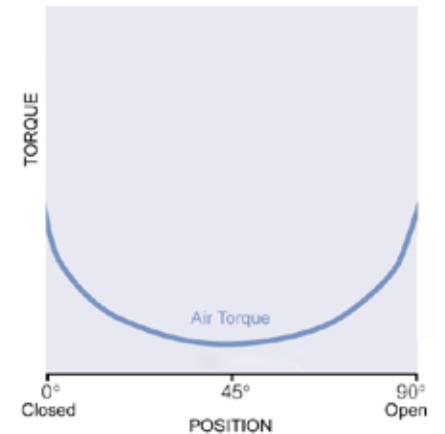

DOUBLE ACTING

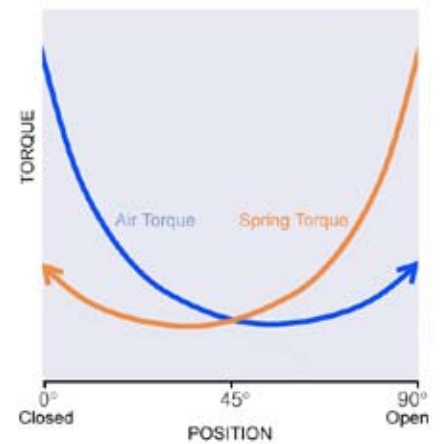

SPRING RETURN

MOUNTING KITS

- Wide range of brackets and drive adapters for any kind of valve.



BRACKETS



DRIVE ADAPTERS

ELECTRIC ACTUATORS

Electric actuators with torques

up to 3.000Nm



ELEMENTS OF REGULATION AND CONTROL

PRISMA offers a wide range of products for valve automation including pneumatic actuators, electric actuators and elements of regulation and control: solenoid valves, limit switch boxes, positioners, travel stops, declutchable gearboxes, handwheels, etc.



MECÁNICA PRISMA, S.L.
C/Telègraf 1-7
Polígon industrial Sota el Molí
08160 - Montmeló (Barcelona)
SPAIN

Tel.: (+34) 93 462 11 54
Fax.: (+34) 93 462 12 74

prisma@prisma.es
www.prisma.es

The logo for Prisma, featuring a stylized blue 'P' symbol followed by the word 'Prisma' in a bold, italicized blue sans-serif font.

Prisma

Technical specifications of our products are available on our website